

COL
LECTION
BOOK

GYFORM

Made in Italy

INDICE / INDEX

01.

AZIENDA / COMPANY

- 006 Profile
- 012 Showroom
- 016 Production

02.

DIVANI / SOFAS

- 028 Boss
- 038 Smart
- 046 Focus
- 056 Planet
- 068 Ghost
- 082 Eliot
- 090 Zelig
- 102 Plan
- 112 Eagle
- 122 Zoe
- 132 Longisland
- 140 Broadway
- 150 Nano
- 156 Athos

- 163 Athos Mini
- 164 Domino
- 170 Egoista
- 176 Big Ben
- 180 Composit
- 184 Doge
- 188 Mito A
- 192 Mixer New
- 196 Mixer Mini

03.

LETTI / BEDS

- 200 Plan Letto

04.

POLTRONCINE / ARMCHAIRS

- 210 Chanel
- 212 Sophie
- 214 Gaia
- 216 Giò
- 218 Megane

- 220 Chica
- 228 Butterfly
- 232 Venus
- 236 Bobo
- 238 Enigma
- 240 Natalie
- 242 Mix
- 244 Queen
- 246 Clio

05.

COMPLEMENTI / COMPLEMENTS

- 250 Break
- 251 Azalea Break
- 252 Molly
- 254 Ego
- 255 Cubo

06.

DATI TECNICI / TECHNICAL DATA

01.

AZIENDA
COMPANY

Company Profile

La storia della Gyform nasce a Vigo Rendena, in Trentino, alla fine degli anni '50 per iniziativa del signor Guido Gasperi. Fin dall'inizio la produzione si è basata su principi guida ben definiti: qualità di progetto sia tecnica che estetica, eco-compatibilità e tradizione, ma anche continua innovazione e visione verso il domani.

The history of Gyform was born in Vigo Rendena, in Trentino in the late 50's with the initiative of Mr. Guido Gasperi. From the beginning, manufacturing was based on well-defined guiding principles: quality and tradition, as well as continuous innovation and vision towards the future.

In den späten 50ern wurde Gyform durch Herrn Guido Gasperi in Vigo Rendena gegründet. Von Anfang an war es die Vision Polstermöbel mit hoher Qualität, extravagantes Design in handwerklicher Tradition zu produzieren. Diese Leitlinien hat sich das Unternehmen aus dem italienischen Trentino bis heute bewahrt.

L'histoire de Gyform commence à Vigo Rendena, dans le Trentino, à la fin des années 50 à l'initiative de M. Guido Gasperi. Dès le début, la production est basée sur des principes directeurs bien définis: la qualité et la tradition, ainsi que l'innovation permanente ainsi que la vision vers l'avenir.

Attraverso una produzione elegantissima di divani e poltrone, Gyform è diventata un punto di riferimento per l'arredamento di alta gamma in tutto il mondo. Un metodo di lavoro che conserva l'antica cultura dei maestri tappezzieri, coniugandola con l'innovazione tecnologica delle linee di produzione.

Thanks to an elegant fabrication of sofas and armchairs, Gyform has become a benchmark for high-end furnishings all over the world. Gyform uses a working method that preserves the ancient culture of master upholsterers and combines it with the continuous technological innovation of the production lines.

Aufgrund seiner ausgefeilten Produktlinie sowie der teilweise patentierten Funktionen in den Sofas und Sesseln hat sich Gyform weltweit ansehen verschafft. Dank der hohen Produktqualität und der innovativen Techniken arbeiten Architekten und Einrichter auf der ganzen Welt mit der Kollektion.

Grâce à une production élégante de canapés et fauteuils, Gyform est devenu une référence pour les meubles haut de gamme dans le monde. Une méthode de travail qui préserve la culture ancienne de maîtres tapissiers, en la combinant avec l'innovation technologique des lignes de production.



Lo stabilimento occupa un'area complessiva di 10.000 metri quadrati dove trovano spazio oltre ai reparti produttivi, anche l'area Ricerca & Sviluppo dedicata all'ingegnerizzazione dei prodotti e prototipi, ed un'esposizione interna a disposizione di operatori e professionisti.

Today, Gyform's factory covers a total area of 10.000 square meters where, in addition to the factory floor, there is an area devoted to research and development and product engineering prototypes, as well as a showroom available to staff and trade professionals.

Heute produziert Gyform auf einer Gesamtfläche von 10.000 m² und konnte die neu realisierten Räumlichkeiten die aufgrund der permanenten Expansion benötigt wurden vor kurzem beziehen. Die gesamte Entwicklung und Engineering befindet sich wie auch der 1000 m² Große Showroom in unmittelbarer Nähe zur Produktion.

L'usine occupe une superficie totale de 10.000 mètres carrés, où on trouve en plus des services de production, la zone dédiée à la recherche en ingénierie et développement de produits et de prototypes, et l'exposition interne disponible pour les designers et les professionnels.





La facciata esterna è rivestita con una lega speciale di rame e zinco. Il prodotto che ne deriva è un materiale che cambia aspetto in modo del tutto suggestivo ed unico quando esposto agli agenti atmosferici.

The material used for the exterior facade is a special alloy of copper and zinc. The result is a robust material that changes dramatically when exposed to the elements.

Die sehr imposante Aussenfasade aus einer speziellen Legierung aus Kupfer und Zink verleiht dem Gebäude seine unverwechselbare Ausstrahlung und unterstreicht durch den gewollten Oxidationsprozess des Metalls den Wechsel der Zeit.

La façade extérieure est revêtue d'un alliage spécial de cuivre et de zinc. Le produit résultant est un matériau qui change d'aspect de façon impressionnante et unique lorsqu'elle est exposée aux agents atmosphériques.



GYFORM IN THE WORLD



Dealers

Austria
Azerbaijan
Bahrain
Belgium
China
Cyprus
Czech Republic
France
Germany
Ghana
Greece

Hong Kong
Iceland
India
Ireland
Italy
Kazakhstan
Kuwait
Lebanon
Liechtenstein
Luxembourg
Netherlands

Nigeria
Poland
Russian Federation
Saudi Arabia
Singapore
Slovakia
Suisse
Ukraine
United Kingdom
UAE
USA

Company Showroom

Il 2013 ha visto l'inaugurazione di un nuovo show-room di 1000 metri quadrati distribuito su due piani con sala riunioni, servizi e coffee-room, oltre a due nuovi magazzini ed un deposito pellami per altri 1500 metri complessivi, che si vanno ad aggiungere ai 5000 metri quadrati coperti già esistenti. Classificato come "energy zero", il nuovo stabile è in grado di utilizzare pochissima energia per il suo funzionamento seguendo criteri costruttivi all'avanguardia.

The year 2013 saw the opening of a new showroom spanning 1,000 square meters on two floors with meeting rooms, eating amenities, as well as two new warehouses for storing of leather which adds another 1,500 meters which adds 5,000 square meters of covered area that already exist. Classified as "zero energy", the new facility is able to use the least amount of energy for its operation following a highly developed construction criteria which makes it sustainable.

Die Eröffnung des neuen Showroom im Jahre 2013 stellte einen weiteren Meilenstein in der kontinuierlichen Entwicklung des Unternehmens dar. Auf 2 Etagen können interessiertes Fachpublikum, Fachhändler und Architekten sich einen Überblick ueber die gesamte Kollektion verschaffen. Bei der Realisierung des Gebäudes wurde besonders auf Nachhaltigkeit geachtet und das Gebäude komplett im Null Energie Standard errichtet.

2013 a vu l'inauguration d'une nouvelle salle d'exposition de 1000 mètres carrés sur deux étages avec une salle de réunion, des services et un bar d'accueil, ainsi que deux nouveaux entrepôts et un stockage cuirs pour un autre, 1500 mètres au total. Classée comme "zéro énergie", la nouvelle usine est en mesure d'utiliser très peu d'énergie pour son fonctionnement suivant des critères de conception d'avantgarde.





All'interno, un'esposizione all'insegna della contaminazione tra architettura, arte e design, caratterizzata dall'atmosfera calda e accogliente data dall'utilizzo di materiali naturali quali il legno e la pietra. Un contesto elegante destinato ad ospitare le collezioni dell'azienda ma anche punto di incontro e formazione per clienti, architetti e designer.

Inside, the interaction of architecture, art and design produce a superb exhibit. The visitor is captivated by the inviting atmosphere, through the use of natural materials such as wood and stone. An elegant setting to display the collections, which also provides a meeting and training center for clients, architects and designers.

Die Absicht die Bereiche Architektur, Kunst und Design harmonisch miteinander zu verbinden wurde in den Ausstellungsräumen durch die geschickte Kombination natürlicher Materialien wie Holz und Stein sowie die geschickte Verbindung von Moderne und Tradition realisiert. Ein Ort der Begegnung für Interessierte rund um das Thema Design, Architektur und Möbel.

A l'intérieur, une exposition est consacrée à l'accord entre l'architecture, l'art et le design. L'atmosphère est chaleureuse et accueillante grâce à l'utilisation de matériaux naturels comme le bois et la pierre. Un cadre élégant pour abriter les collections de l'entreprise, mais aussi un lieu de rencontre et de formation pour les clients, les architectes et les designers.



Production Process

In Italia e all'estero Gyform è sinonimo di qualità. Ogni dettaglio è curato nel particolare. Ogni pezzo è realizzato in ogni sua componente da materiali di primissima qualità. Le strutture dei divani sono esclusivamente in legno massello di faggio, pioppo, pino o abete, con particolari di sostegno in multistrato, ed assemblate manualmente per garantire durabilità nel tempo.

In Italy and abroad, Gyform is synonymous with quality. Every detail is precisely designed, and each component is made from the highest quality materials. The structures of sofas are exclusively made of solid beech, poplar, pine or spruce, all with multi-layered special support and assembled by hand to ensure durability.

Gyform ein Synonym für Design und Qualität weit über die Grenzen Italiens hinaus. Jedes Detail ist genauestens geplant und wird durch Fachleute mit jahrelangem Know-How liebevoll verarbeitet. So verwendet Gyform ausschließlich hochwertigste Materialien von massiven Rahmenkonstruktionen bis hin zu natürlichen Ledern für die Erstellung dieser zeitlos eleganten Möbel.

En Italie et à l'étranger Gyform est synonyme de qualité. Chaque détail est conçu avec un soin particulier. Chaque pièce est faite avec des matériaux de haute qualité. Les structures de canapés sont fabriqués exclusivement en hêtre massif, peuplier, pour un soutien particulier en multiplis et assemblés à la main pour assurer la durabilité.







Tessuti e pellami vengono meticolosamente controllati da esperti del settore per eliminare eventuali imperfezioni ed essere avviati alle operazioni di taglio. Una volta tagliate le dime, ogni singolo pezzo viene nuovamente supervisionato. Ordine alla mano, si ricompongono i tagli da inviare al reparto cucitura, dove il personale altamente specializzato si occupa delle finiture.

Fabrics and leathers are meticulously checked by experts to exclude any imperfections and to be prepared for cutting operations. Once cut, each piece is again supervised for consistency and quality control. The cut segments are then sent to the sewing department, where highly skilled staff take care of the finishing details.

Alle eingesetzten Materialien unterliegen selbstverständlich einer peinlich genauen Prüfung durch unsere Experten und werden nur nach unseren Vorgaben produziert und anschließend Verarbeitet.

Tissus et cuirs sont méticuleusement vérifiées par des experts afin d'éliminer toutes les imperfections avant de procéder à des opérations de coupe. Une fois coupée, chaque pièce est de nouveau supervisée. Commande dans la main, elles sont recomposées avant d'être envoyé au département de couture, où un personnel hautement qualifié prend soin des finitions.

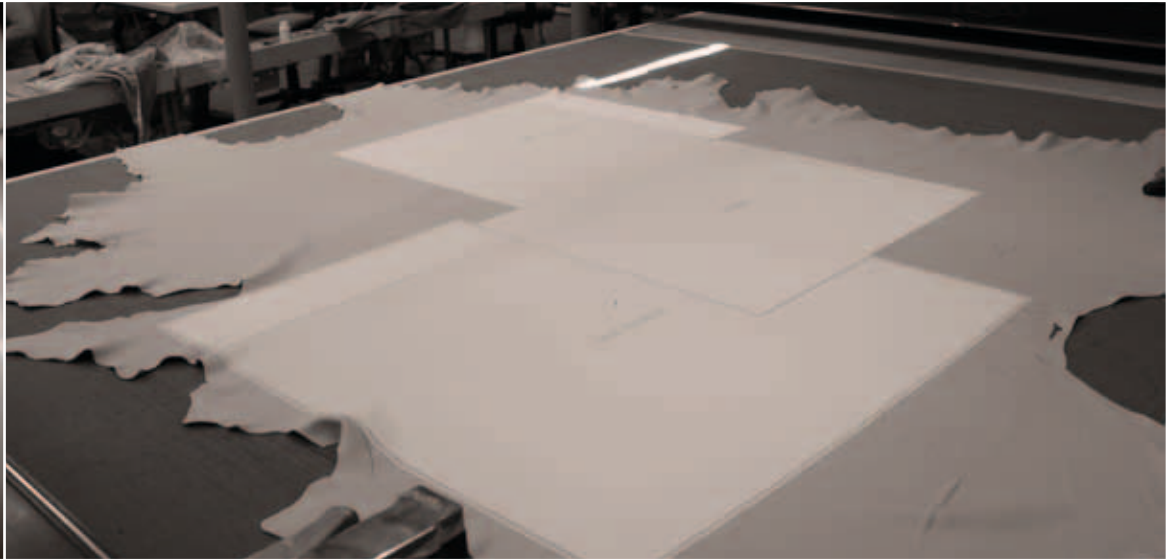

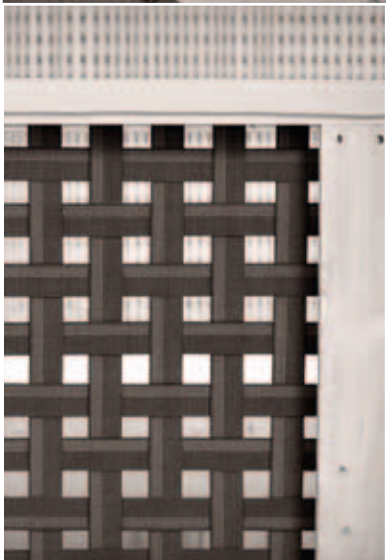

Nel reparto di assemblaggio il prodotto assume la sua configurazione definitiva e subisce un ultimo meticoloso controllo prima di essere avviato al settore spedizioni. Ciascun materiale impiegato nella fabbricazione viene sottoposto a diversi test per accertarne la resistenza e la durata nel tempo. Una ricerca attenta anche dal punto di vista ecologico, con la limitazione e/o l'eliminazione di contaminanti chimici.

In the assembly department the product takes its final form and undergoes a thorough final inspection before being sent to the shipping section. Each material used in the fabrication is subjected to various tests to determine the resistance and the durability. A careful inspection is also carried out from the ecological point of view, with the limitation and / or elimination of chemical contaminants.

Verarbeitet in handwerklicher Tradition, italienische Design, nachhaltige Produktion, hochwertige Materialien das sind einige Key-Facts der Möbel die dazu beitragen aus einem Gyform Möbel ihr persönliches Lieblingsstück zu kreieren.

Dans le département d'assemblage, le produit prend sa forme définitive et subit une inspection finale approfondie avant d'être envoyé à l'industrie du transport. Chaque matériau utilisé dans la fabrication est soumise à divers tests pour déterminer la résistance et la durabilité du produit. Une recherche minutieuse aussi du point de vue écologique, avec la limitation et / ou l'élimination des contaminants chimiques.









02.

DIVANI
SOFAS

BOSS

design Alessia Gasperi

Un sistema di sedute che si distingue per le linee essenziali, le forme rigorose, la spiccata eleganza e le proporzioni contemporanee. Dodici posizioni per braccioli e schienali, che in orizzontale possono diventare un funzionale piano d'appoggio. Sofisticati piedini color bronzo sostengono la base.

A seating system that is distinguished by clean lines, strict forms, distinct elegance and contemporary proportions. Twelve positions for armrests and backrests, which can be horizontal and become a functional surface. Sophisticated bronze feet support the base.

Ein Sitzsystem, das sich durch klare Linien, eine elegante Formensprache, ein hohes Maß an Eleganz und zeitgemässe Proportionen auszeichnet. In zwölf Positionen sind Arm und Rückenlehnen zu verstellen. Die raffiniert gestalteten Füße runden das Markante Design perfekt ab.

Un système de sièges qui se distingue par des lignes pures, des formes harmonieuses, élégantes et contemporaines. Douze positions pour accoudoirs et dossiers, qui peuvent devenir horizontaux et offrir une surface fonctionnelle. Pieds sophistiqués de base de support en bronze.









Divano Boss 280 cm in pelle San Diego castagno 52110 cat.4 con appoggiareni trapuntati e 2 cuscineti 55x55 cm con fascia in velluto palma 363/03 cat.C; 2 poltroncine Chanel in velluto acquamarina 363/40 cat.C con piedi wenge'.

Boss sofa 280 cm in leather San Diego Castagno 52110 cat.4 with kidney rest pillows quilted in contrast stitching and 2 pillows 55x55 cm in Velvet Palma 363/03 cat.C; 2 Chanel armchairs in Velvet Acquamarina 363/40 cat.C wenge legs.



Sofa Boss 280 cm in Leder San Diego castagno 52110 Kat.4 mit Nierenkissen gesteppt mit Kontrast-Naht und 2 Kissen 55x55 cm in Velour palma 363/03 Kat.C; 2 Sessel Chanel Velour acquamarina 363/40 Kat.C. Fusse wenge.

Canapé Boss 280 cm cuir San Diego castagno 52110 cat.4 avec coussins callerein matelassé et 2 coussins 55x55 cm en velour palma 363/03 cat.C; 2 fauteuils Chanel velour acquamarina 363/40 cat.C avec pieds hêtre teite wenge.







Terminale Boss 208 cm sinistro e chaise longue 160x122 cm destra in tessuto damina sabbia 560/03 cat.E con appoggiareni ceniglia unito sabbia 561/03 e struttura in pelle Prescott grey 304 cat.3; 2 cuscinetti 55x55 cm in tessuto bicolore castoro 563/06 cat.E; piedini bronzati.

Boss terminal 208 cm left and chaise lounge 160x122 cm right in fabric Damina Sabbia 560/03 cat.E with kidney rest pillows Ceniglia Unito Sabbia 561/03; frame in leather Prescott Grey 304 cat.3; 2 pillows 55x55 cm fabric Bicolor Castoro 563/06 cat.E; legs bronze.

Endelement Boss 208 cm Links und Liege 160x122 cm rechts in Stoff damina sabbia 560/03 Kat.E mit Nierenkissen ceniglia unito sabbia 561/03; Gestell aus Leder Prescott grey 304 Kat.3; 2 Kissen 55x55 cm Stoff bicolore castoro 563/06 Kat.E; Fusse bronze.

Terminal Boss 208 cm gauche et chaise longue Boss 160x122 cm droite tissu damina sabbia 560/03 cat.E avec coussin callerein en ceniglia unito sabbia 561/03; carcasse en cuir Prescott grey 304 cat.3; 2 coussins 55x55 cm tissu bicolore castoro 563/06 cat.E; pieds metal finition bronz.



L'estensione formale della base che fuoriesce lateralmente e posteriormente si presta ad essere vissuta ed attrezzata liberamente con vassoi e librerie in cuoio, creando un interessante gioco di volumi con un'alternanza di pieni e vuoti.

The formal extension of the base coming out of the side and back is suitable to be lived freely and equipped with trays and book shelves in leather, creating an interesting play of volumes with an alternation of solids and voids.

Die reizvollen Freiflächen an den Korpus Seiten eignen sich zur individuellen Gestaltung durch optionale Tablettts oder Bücherregale Leder. Hier kreieren Sie Ihr eigenes Design.

L'extension de la base sortant sur les côtés et à l'arrière peut être utilisée librement selon son envie et équipée avec des plateaux et des bibliothèques en cuir, créant un jeu intéressant de volumes avec une alternance de pleins et de vides.



Smart

design Alessia Gasperi

Un divano dalle proporzioni contemporanee, la cui linearità delle forme è impreziosita ed esaltata dal dettaglio stilistico della struttura che lo mantiene sospeso. Un abbinamento armonioso in grado di renderlo protagonista della zona living.

A sofa with contemporary proportions, whose linear forms are enriched and enhanced by stylized details of the structure that keeps it suspended. A harmonious combination which can make the living area a protagonist.

Ein modernes Sofa mit spannenden Proportionen, die lineare Formen kombiniert mit den stilistischen Details und dem schwebenden Rahmen machen die Linie Smart zu einem ganz besonderen Möbel. Ein Möbel für Individualisten.

Un canapé avec des proportions contemporaines, dont la forme linéaire est enrichie et améliorée par des détails de style de la structure qui donne un effet de suspension. Une combinaison harmonieuse peut se faire dans la salle de séjour.









Terminale Smart 222 cm destro, chaise longue 155x120 cm sinistra in tessuto ceniglia spigato ghiaccio 562/02 cat.E con struttura sedile in pelle linea asfalto 660 cat.4; 3 cuscini schienale 75x55 cm in tessuto 562/02 e 2 cuscinetti 50x50 cm in ceniglia bicolore ghiaccio 563/02 cat.E. Piedini bronzo. 2 poltroncine Sophie in pelle Linea asfalto 660 cat.4 con piedi wengè.

Smart terminal 222 cm right arm, chaise longue 155x120 cm left in fabric Ceniglia Spigato Ghiaccio 562/02 cat.E with seat frame in leather Linea Asfalto 660 cat.4; 3 back cushions 75x55 cm in fabric 562/02 cat.E and 2 Smart pillows 50x50 cm fabric Ceniglia Bicolor Ghiaccio 563/02 cat.E. Legs bronze. 2 Sophie armchairs in leather Linea Asfalto 660 cat.4 with wenge legs.

Endelement Smart 222 cm rechts, Liege 155x120 cm links in Stoff ceniglia spigato ghiaccio 562/02 Kat.E mit Gestell in Leder Linea asfalto 660 kat.4; 3 Rueckenkissen 75x55 cm in Stoff 562/02 kat.E und 2 lose kissen 50x50 cm Stoff ceniglia bicolore ghiaccio 563/02 Kat.E. Fusse bronziert. 2 Sessel Sophie in Leder Linea asfalto 660 Kat.4 Fusse wengè.

Terminal Smart 222 cm droite et chaise longue 155x120 cm gauche en tissu ceniglia spigato ghiaccio 562/02 cat.E avec carcasse assise en cuir Linea asfalto 660 cat.4; 3 coussins dossier 55x55 cm en tissu 562/02 cat.E et 2 coussins 50x50cm tissu ceniglia bicolore ghiaccio 563/02 cat.E. Pieds bronz. 2 fauteuil Sophie en cuir Linea asfalto 660 cat.4 pieds hêtre teinte wengè.

02 / SOFAS / **SMART**

Dettaglio base bronzata Smart.

Detail bronzed base.

Detail Basis bronziert.

Détail Pied metal finition bronz.







Divano Smart 244 cm in pelle nabuk grigio con 2 cuscini schienale da 75x55 cm e 2 cuscinetto in velluto azzurro 47x47 cm; poltroncina Gaia in velluto azzurro e base wenge'.

Smart sofa 244 cm in Grey Nabuk leather with 2 back cushions 75x55 cm and 2 pillows Light Blue velvet 47x47 cm; Gaia armchair with wenge base.

Sofa Smart 244 cm in Leder grau nabuk mit 2 Rueckenkissen 75x55 cm und 2 lose Kissen Velour hell blau 47x47 cm; Sessel Gaia mit Basis Wenge'.

Canapè Smart 244 cm cuir nubuk gris avec 2 coussins dossiers 75x55 cm et 2 coussins 47x47 cm; fauteuil Gaia structure en bois hêtre teinte wenge'.

Focus

design Studio Tecnico Gyform

Forme abbondanti e morbidi volumi si fondono in un insieme di linee pulite ed essenziali. Una risposta concreta per personalizzare il proprio comfort attraverso l'innovativo meccanismo di prolungamento della seduta e gli schienali reclinabili in dodici diverse posizioni.

Abundant shapes with a soft volume come together in a set of clean lines. A practical response to customize your comfort through the innovative mechanism of prolonged sitting and reclining backrests in twelve positions.

Zeitgemässe Formen kombiniert mit weichen Linien. Eine konkrete Antwort für Ihr Wohlbefinden, durch die innovative Sitzverlängerung Mechanismus und die Rueckenteil mit zwölf verstellbaren Positionen. Die Details, wie die Verarbeitung der Nähte sind Kennzeichen für Exklusivität und Eleganz.

Formes généreuses et faibles volumes sont réunis dans un ensemble de lignes épurées. Une réponse concrète à personnaliser votre confort à travers le mécanisme innovant de position assise prolongée et dossiers inclinables en douze positions.









Dettaglio seduta relax estraibile fino a 50 cm e meccanismo schienale con 12 diverse inclinazioni e con nuova tecnologia "senza piega".

Detail of backrests adjustable in 12 positions with the new "no fold marks" technology and seats that can be extended out up to 50 cm.

Rückenkissen, verstellbar in 12 verschiedene Positionen mit neuer Technologie "Faltenlos". Die Sitzkissen sind mittels pantentiertem Mechanismus bis zu 50 cm auziehbar. Dadurch erhalten Sie eine optimale Relaxposition.

Détail d'assise relax réglable jusqu'à 50 cm, dossier relevable avec mécanisme avec 12 positions et avec une nouvelle technologie "sans plis".





Terminale Focus 206 cm sinistro e chaise longue 222x102 cm destra in pelle Toledo topo 2 cat.5 con cuscinetto con rullo da utilizzare come cuscino schienale su bracciolo chaise longue.

Focus left arm terminal 206 cm and right chaise lounge 222x102 cm in leather Toledo Topo 2 cat.5 and cushion with roll to be used as a back cushion.

Endelement Focus 206 cm links und Liege 222x102 cm rechts in Leder Toledo topo 2 Kat.5.

Terminal Focus 206 cm gauche et chaise longue 222x102 cm droite en cuir Toledo topo 2 cat.5 avec coussin rouleau à être utilisé comme un coussin de dossier.







02 / SOFAS / **FOCUS**

Divano Focus 232 cm in pelle Bost grigio chiaro 55036 cat.4 con 2 cuscinetti intreccio Zelig 45x45 cm.

Sofa Focus 232 cm in leather Bost grigio chiaro 55036 cat.4 with 2 pillows woven Zelig 45x45 cm.

Sofa Focus 232 cm in Leder Bost grigio chiaro 55036 Kat.4 mit 2 Kissen geflecht Zelig 45x45 cm.

Canapè Focus 232 cm en cuir Bost grigio chiaro 55036 cat.4 avec 2 coussin tressé Zelig 45x45 cm.





Planet

design Studio Tecnico Gyform

Una proposta dalle linee geometriche e scolpite che determinano una grande personalità all'insegna della massima comodità, grazie agli schienali reclinabili in due posizioni. Un equilibrio di forme essenziali e lineari, dall'eleganza impeccabile, sottolineata da dettagli sartoriali come la cucitura a "punto cavallo".

A design with geometric lines and shapes which leads to a great personality with maximum comfort, thanks to the reclining backrests in two positions.

A balance of essential shapes and lines, impeccable elegance, highlighted by tailoring details like stitching "punto cavallo".

Klare, skulpturale Linien, die eine starke Persönlichkeit mit maximalem Komfort verbinden. Mittels der verstellbaren Rückenlehnen in zwei Positionen wird die Komfortzone realisiert. Die schlichte zeitlose Eleganz und Formensprache gepaart mit handwerklicher Perfektion machen Planet zu einem Bestseller.

Lignes géométriques et travaillées qui déterminent une grande personnalité avec un maximum de confort, grâce aux dossiers inclinables en deux positions.

Un équilibre des formes essentielle et linéaire, l'élégance impeccable, mis en évidence par l'adaptation des détails comme la couture "point de feston".













Terminale Planet 222 cm sinistro e angolo terminale 230x100 cm destro in pelle Vintage warm grey 67009 cat.5 con base tubolare lucida diritta (H 14cm) e cucitura "punto cavallo" in contrasto.

Planet Terminal 222 cm left and right corner terminal 230x100 cm in leather Vintage Warm Grey 67009 cat.5 with polished straight tubular base (H 14cm) and "punto cavallo" stitching.

Endelement Planet 222 cm links und Eckenelement 230x100 cm rechts in Leder Vintage warm grey 67009 Kat.5 mit durchgehendem geradem Gestell, poliert (H 14cm). Nahtausführung: "Punto Cavallo".

Terminal Planet 222 cm à gauche et angle terminal 230x100 cm à droite en cuir Vintage warm grey 67009 cat.5 base tubulaire aluminium avec pieds (H 14cm) et couture "Punto Cavallo".









Composizione angolare Planet 322x230 cm in pelle Vintage warm grey 67009 cat.5. Poltroncina Sophie in pelle Linea asfalto 660 cat.4 con piedi wengè.

*Planet sectional 322x230 cm leather Vintage Warm Grey 67009 cat.5.
Sophie armchair in leather Linea asfalto 660 cat.4 with wenge legs.*

Eckgruppe Planet 322x230 cm in Leder Vintage warm grey 67009 Kat.5. Sessel Sophie in Leder Linea asfalto 660 Kat.4 Fusse Wengè.

*Composition Planet 322x230 cm en cuir Vintage warm grey 67009 cat.5.
Fauteuil Sophie en cuir Linea asfalto 660 cat.4 pieds teinté wengè.*

Dettaglio meccanismo schienale e cucitura "punto cavallo" con filo in contrasto.

Detail headrest mechanism and "punto cavallo" stitching with contrasting thread.

Detail: Rueckenstutze verstellbar und Nähte "punto cavallo" mit Kontrast-Faden.

Détail dossier relevable avec couture "punto cavallo" avec fil contrasté.



Ghost

design Giulio Manzoni

Il design pulito e lineare è accompagnato dal meccanismo esclusivo ed inimitabile di Gyform che consente di estrarre ogni seduta in quattro diverse posizioni con prolunga a scomparsa, con estensione massima di 50 cm. Schienale reclinabile in dodici posizioni e con nuova tecnologia "senza piega".

The clean, linear design is accompanied by a unique and unparalleled mechanism by Gyform that allows every seat to be drawn out in four different positions with hidden extensions, with a maximum extension of 50 cm. Reclining backrest in twelve positions and with the new "no crease" technology.

Das geradlinige Design wird, ergänzt durch einen einzigartigen weltweit patentierten Mechanismus, zu dem besonderen Möbel in Ihrem Wohnraum. Die Sitze können bis zu 50 cm ausgezogen werden, somit wandelt sich Ghost vom Sofa zur Well-Being Zone. In zwölf Positionen verstellbare, Rückenlehnen perfektionieren den Komfort.

Le design linéaire propre est accompagné par un mécanisme de Gyform unique et inimitable qui permet à chaque siège de prendre quatre positions différentes avec une extension interne, avec une extension maximale de 50 cm. Dossier inclinable en douze positions et avec la nouvelle technologie "sans plier".









Terminale Ghost 201 cm sinistro versione bracciolo lungo e chaise longue 222x95 cm destra con seduta a martello in pelle taupe Conan 51020 cat.4 con cuscinetto con rullo da utilizzare come cuscino schienale su bracciolo chaise longue. Tavolino Azalea Break 55x45xH52 cm; pouf Molly 80x80 cm in cavallino laminato bianco 80045; 2 poltroncine Venus in pelle bianca Breezzer 41045 cat.3.

*Terminal Ghost 201 cm with left long arm and chaise longue 222x95 cm right with hammer seat in leather taupe Conan 51020 cat.4 with cushion with roll to be used as a back cushion.
Table Azalea Break 55x45xH52 wengè;
Molly ottoman 80x80 cm in pony white laminate 80045; 2 armchairs Venus in white leather Breezzer 41045 cat.3.*



Endelement Ghost 201 cm links mit
langen Armteil und Liege 222x95 cm
rechts mit Hammer Sitz in Leder Taube
Conan 51020 Kat.4. Das Kissen mit
Rolle wurde als Rückenkissen verwendet.
Tisch Azalea Break 55x45xH52 cm
wengé; Hocker Molly 80x80 cm in
weißem Edel Fell 80045; 2 Sessel Venus
in weißem Leder Brezzer 41045 Kat.3.

*Terminal Ghost 201 cm avec bras long
gauche et chaise longue 222x95 cm droite
avec assise marteau en cuir taupe Conan
51020 cat.4 avec coussin rouleau à être
utilisé comme un coussin de dos.
Tableau Azalea Break wengé 55x45xH52
cm; pouf Molly 80x80 cm en poney blanc
80045 stratifié; 2 fauteuils Venus en cuir
blanc Brezzer 41045 cat.3.*





Terminale 201 cm bracciolo corto e chaise longue 222x95 cm con seduta a martello in pelle Prescott soul white 200 cat.3 con cuscinetto con rullo da utilizzare come cuscino schienale su bracciolo chaise longue.

Terminal 201 cm short arm and chaise longue 222x95 cm with hammer seat effect in leather white Prescott soul white 200 cat.3 and cushion with roll to use as back rest on the arm of the chaise.

02 / SOFAS / GHOST

Endelement 201 cm und Liege 222x95 cm mit Sitz "Hammer" in Leder Prescott soul white 200 Kat.3 und Kissen mit Rolle. Dieses ist als Rückenkissen beim Armteil der Liege zu benutzen.

Terminal 201 cm et chaise longue 222x95 cm en cuir Prescott soul white 200 cat.3 avec coussin avec rouleau à utiliser comme coussin de dossier sur l'accoudoir de la chaise longue.











02 / SOFAS / GHOST

Divano 222 cm con dettaglio seduta relax estraibile fino a 50 cm e meccanismo schienale con 12 diverse inclinazioni e con nuova tecnologia "senza piega".

Sofa 222 cm with detail of backrest adjustable in 12 positions with the new "No Fold Marks" technology and seat that can be extended out up to 50 cm.





Sofa 222 cm mit Detail vom Rücken-
kissen. Verstellbar in 12 verschiedenen
Positionen mit der neuen Technologie
"Faltenlos". Das Sitzkissen ist mittels
Mechanismus für die Relaxposition bis
50 cm nach vorne ausziehbar.

*Canapé 222 cm avec détail d'assise relax
réglable jusqu' à 50 cm, dossier relevable
avec mécanisme avec 12 inclinaison et
avec une nouvelle technologie "sans pli".*

Eliot

design Studio Tecnico Gyform

Un divano esclusivo nel segno della leggerezza, che si distingue per lo stile moderno ed essenziale. Il fianco del bracciolo può essere liscio o trapuntato con cuciture realizzate tono su tono oppure con colori a contrasto, che diventano motivo distintivo.

A exclusive sofa focused on lightness, which is distinguished by its simple, modern style. The side of the armrest can be smooth or quilted, seams made with matching or contrasting colors, which become a distinctive theme.

Ein Sofa das durch Transparenz und Leichtigkeit besticht. Passend zu jeder Stilrichtung können die Armteile jeweils in glatt oder mit Steppnähten ausgeführt werden. Die Steppnähte können durch Kontrastfäden markant in Szene gesetzt werden.

Un canapé-exclusif pour sa légèreté, qui se distingue par son style simple et moderne. Le côté de l'accoudoir peut être avec des coutures lisses ou matelassés en ton sur ton ou des couleurs contrastées, ce qui permet un motif distinctif.









Dettaglio dei cuscinetti 46x46 cm in pelle trapuntata, piedino in acciaio lucido e fianco bracciolo trapuntato (disponibile anche liscio).

Detail of the pillow 46x46 cm "quilted", legs in steel polished and armside quilted (available even plain).

Detail Kissen "gesteppt" 46x46 cm, FüÙe in Edelstahl poliert und Außenseite der Armlehne gesteppt (auch ohne Steppung lieferbar).

Détail coussin «matelassé» 46x46 cm, pieds en acier chromé et extérieur de l'accoudoir matelassé losange (disponible tendu).



Terminale Eliot 205 cm sinistro e chaise longue 145x105 cm destra in pelle Toledo Tabacco col. 4 cat.5 con cuscinetti 46x46 cm in pelle trapuntata.

Eliot Terminal 205 cm left arm and right chaise longue 145x105 cm leather Tobacco Toledo 4 cat.5 with 2 pillows 46x46 cm "quilted".

Endelement Eliot 205 cm links und Liege 145x105 cm rechts Leder Tabak Toledo 4 Kat.5 mit zwei Kissen "gestept".

Terminal Eliot 205 cm à gauche et chaise longue 145x105 cm à droite en cuir tabac Toledo 4 cat.5 avec 2 coussin «matelassé» 46x46 cm.







Zelig

design Studio Tecnico Gyform

Un design elegante dalle linee pulite ed essenziali, caratterizzato da piedini in acciaio alti 18 cm che sollevano la struttura per un effetto di estrema leggerezza. Un divano scelto da chi ama la modernità, da chi preferisce gli arredi che nascondono la loro solidità dietro ad un'immagine leggera.

A sleek design with clean lines, characterized by tall steel feet 18 cm that lift the structure for an effect of lightness and gracefulness. A sofa chosen by those who love modern forms, from those who prefer furnishings that cover their strength with an elegant image.

Das schlanke Design einer klaren Linienführung kennzeichnet Zelig. Seine Leichtigkeit zeichnet diese Linie aus und kennzeichnet einen modernen zeitlosen Trend. Ein Sofaprogramm das aufgrund seiner Vielfalt dem Gestalter jegliche Freiheit einräumt und sich unaufgeregt an jede Einrichtungssituation anpasst.

Un design élégant aux lignes épurées, caractérisé par des pieds en acier chromé hauts 18 cm qui soulèvent la structure pour un effet de l'extrême légèreté. Un canapé choisi par ceux qui aiment la modernité, et ceux qui aiment les meubles modernes et pleins de luminosité.













Terminale Zelig 205 cm destro e chaise longue 145x105 cm sinistra in pelle Toledo Tabacco col. 4 cat.5 con cuscinetti appoggia reni da 70 cm (di serie) e 1 cuscinetto "treccia" 45x45 cm in pelle Toledo Marmotta 03 cat.5.

Zelig Terminal 205 cm right and left chaise longue 145x105 cm leather Tobacco Toledo 4 cat.5 with kidney rest pillows 70 cm and 1 pillow "woven" 45x45 cm leather Toledo 03 cat.5.



Endelement Zelig 205 cm rechts und
Liege 145x105 cm Leder Tabak Toledo
4 Kat.5 mit Nierenkissen 70 cm und
ein Kissen "geflecht" Leder Toledo
Marmotta 03 Kat.5.

*Terminal Zelig 205 cm à droite et chaise
longue 145x105 cm à gauche en cuir
tabac Toledo 4 cat.5 avec cale-reins de 70
cm (inclus). Coussin «tressé» 45x45 cm
en cuir Toledo coloris 03 Marmotta cat.5.*









02 / SOFAS / ZELIG

Divano Zelig 250 cm in tessuto soft corda 429/05 cat.D con cuscinetti appoggia reni (di serie) e 2 cuscinetti 50x50 cm in tessuto lucido marmotta 426/07 cat.D.

Sofa Zelig 250 cm fabric soft corda 429/05 cat.D with kidneyrest pillows (standard) and 2 pillows 50x50 cm in shiny fabric 426/07 marmotta cat.D.

Sofa Zelig 250 cm Stoff "Soft" 429/05 Kat.D mit Nierenkissen (Standard) und 2 Kissen 50x50 cm in glänzendem Stoff Marmotta 426/07 Kat.D.

Canapé Zelig 250 cm en tissu "Soft" coloris corde 429/05 cat.D avec coussins cale-reins (inclus) et 2 coussins 50x50 cm en tissu brillant coloris marmotte 426/07 cat.D.



Plan

design Studio Tecnico Gyform

Una proposta dalle forme essenziali in perfetto equilibrio tra design minimale ed eleganza. Schienali reclinabili in due posizioni (alta o bassa) e due differenti versioni di braccioli in piena coerenza con un progetto di total comfort.

A concept of a basic shape in perfect balance between elegance and minimal design. Reclining backrests in two positions (high or low) and two versions of armrests fully in line with a proposed total comfort.

Ein Sofaprogramm in perfekte Balance zwischen Eleganz und minimalistisches Design. Verstellbaren Rückenlehnen in zwei Positionen (hoch oder niedrig) und verschiedene Versionen der Armlehnen runden diesen Klassiker perfekt ab.

Une proposition pour une forme de base dans un équilibre parfait entre élégance et design minimaliste. Dossiers Inclinables en deux positions (haute ou basse) et deux versions d'accoudoirs totalement en ligne donnant un confort total.









Dettaglio meccanismo
cuscino schienale.

*Detail mechanism
backrest cushion.*

Detail Rückenkissen,
Mechanismus verstellbar.

*Détail du mécanisme
du coussin de dossier.*



Terminale 230 cm sinistro e angolo terminale 230x100 cm destro in pelle pura anilina anilux 61006 con base tubolare in alluminio lucido.

Left arm facing sofa 230 cm and right arm corner terminal 230x100 cm in pure aniline leather dark brown anilux 61006 with tubular base polished.

Endelement 230 cm links und Eckelement 230x100 cm rechts im rein Anilin Leder Anilux 61006 dunkelbraun mit durchgehenden Fuß Gestell Alu poliert.

Terminal gauche 230 cm et angle terminal droite 230x100 cm en cuir brun foncé Anilux 61006 avec socle en aluminium brillant.



Dettaglio cuscini schienale angolo terminale.

Detail backrest cushion corner terminal.

Detail des Rückenkissen von Eckenelement.

Détail de coussins de dossiers d'angle terminal.





Divano "Plan 24" da 284 cm con bracciolo basso sinistro da 60 cm in pelle pura anilina anilux 61006 testa di moro; base tubolare in alluminio lucido.

Sofa "Plan 24" 284 cm with left large arm 60 cm in leather pure aniline dark brown anilux 61006; tuolar base aluminium polished.

Sofa "Plan 24" 284 cm breit mit niedrigen Armteil links 60 cm in Leder rein Anilin anilux 61006 mit durchgehenden Gestel Alluminium poliert.

Canapé "Plan 24" 284 cm avec accouoir gauche bas large 60 cm en cuir pure aniline anilux 61006 brun foncé cat.4; socle en aluminium brillant.

Particolare base tubolare in alluminio lucido. Particolare piedino "Lama".

Detail of tubular base aluminium polished. Detail edge leg.

Detail durchgehende Basis.
Detail winkelfuß.

*Détail socle en aluminium luisant.
Détail de pied lama "L".*





Terminale 230 cm sinistro e chaise longue
230x100 cm destra in pelle pura anilina
Oasis bianco latte 65045 cat.5 con 2
cuscinetti con fascia 55x55 cm; piedi a
lama in alluminio lucido.

*Left arm facing sofa 230 cm and right
arm chaise longue 230x100 cm in leather
pure aniline white Oasis 65045 cat.5
with 2 loose pillows 55x55 cm; edge legs
polished.*

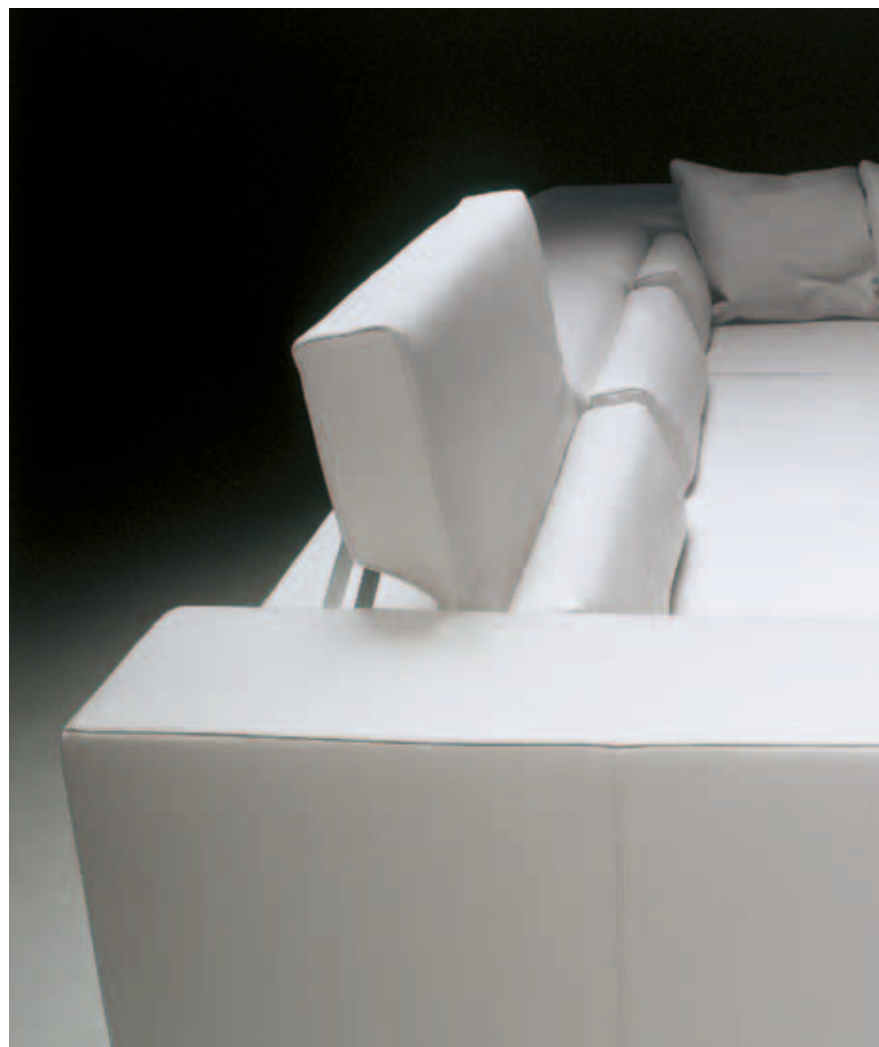



Endelement 230 cm links und Liege
230x100 cm rechts im Leder rhein anilin
weiss Oasis 65045 Kat.5 mit 2 lose
Kissen mit Steg 55x55 cm; Winkelfuß alu
poliert.

*Terminal gauche 230 cm et chaise longue
droit 230x100 cm en cuir blanc Oasis
65045 cat.5 et 2 coussin avec plate band
55x55 cm; pieds lama "L" aluminium
brillant.*

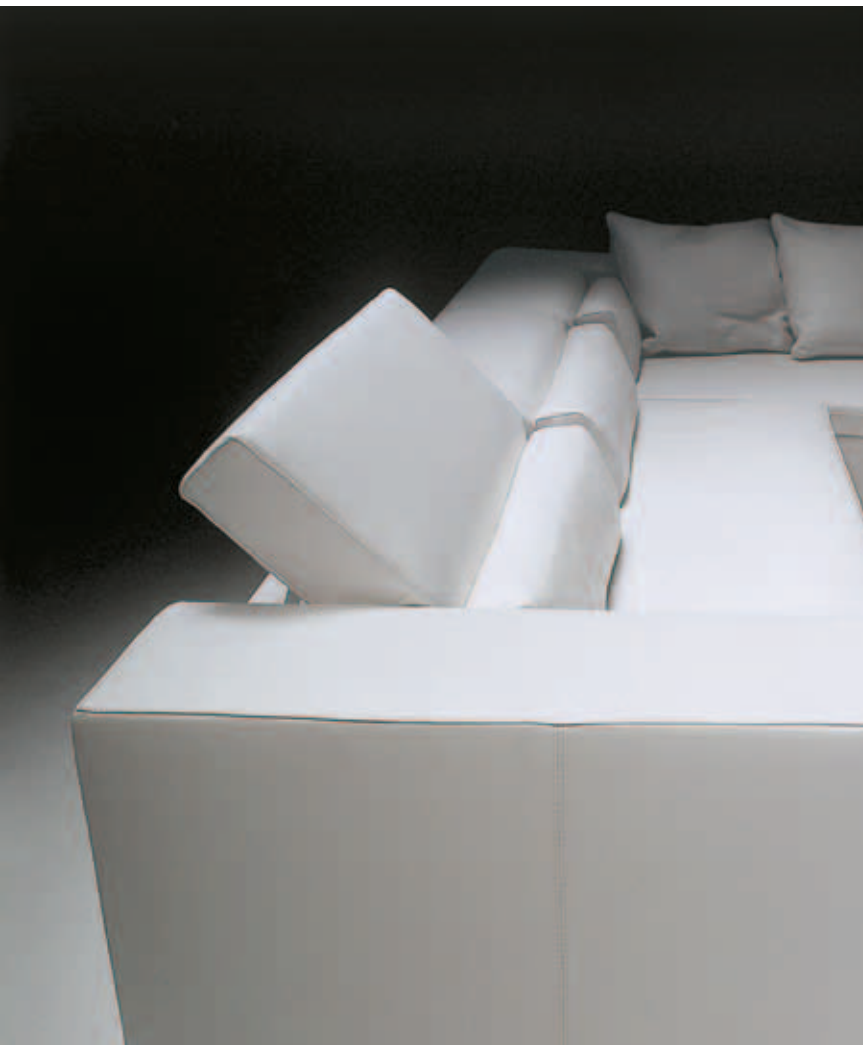

Eagle

design Studio Tecnico Gyform

Una raffinata sobrietà che si sposa con morbidezza e comfort. Minimalismo e purezza formale, per un sistema di sedute essenziale, preziosamente semplice e decisamente comodo. I piedini in alluminio satinato mantengono il divano sollevato da terra, accentuandone l'eleganza.

A refined design which is combined with soft shapes and comfort. Minimalism and purity of form, essential to a seating system, made beautifully simple and remarkably comfortable. The feet in satin aluminum keep the sofa off the ground, accentuating its elegance.

Minimalismus und Klarheit in der Formensprache ist, für eine Sitzsystem unerlässlich, kostbar einfach und sehr komfortabel sind die Attribute von Eagle. Die Füße aus Aluminium lassen das Sofa über dem Boden schweben.

Une simplicité raffinée qui allie douceur et confort. Minimalisme et pureté de la forme, pour un système essentiel, rigoureusement simple et offrant des sièges extrêmement confortables. Les pieds en aluminium satiné surelevant le canapé du sol en accentuant l'élégance.









02 / SOFAS / EAGLE

Divano Eagle 240 cm e terminale 200 cm destro in tessuto mistolino bianco 553/01 cat.E con 2 cuscineti 46x46 cm in tessuto mistolino perla 553/15, 2 cuscineti 46x46 cm in tessuto mistolino creta 553/14 e 2 cuscineti 46x46 cm in tessuto mistolino elefante 553/14 (su richiesta è possibile avere anche un cuscino schienale da 50 cm da usare come cuscino schienale angolo).

Sofa Eagle 240 cm and terminal right 200 cm in white linen mix fabric 553/01 cat.E with 2 loose pillows 46x46 cm fabric 553/15 pearl, with 2 loose pillows 46x46 cm fabric linen mix Crete 553/14 and 2 loose pillows 46x46 cm linen mix elephant 553/14 (on request it is possible to have a backrest cushion from 50 cm to use as a corner backrest cushion).

Sofa Eagle 240 cm und Endelement rechts 200 cm in weißem Stoff 553/01 Kat.E. Dazu 2 lose Kissen 46x46 cm in Stoff Perle 553/15, 2 lose Kissen 46x46 cm in Stoff Kreta 553/14 und 2 lose Kissen 46x46 cm Elephant 553/14 (auf Anfrage ist es möglich, dass für die Rückenlehne ein Kissen von 50 cm als Rückenkissen für die Ecke verwendet werden kann).

Terminal 200 cm à droite et canapé Eagle 240 cm en tissu 553/01 lin et viscose blanc Cat.E avec 2 coussins 46x46 cm tissu 553/15 perle, 2 coussins tissu Crète 553/14 et 2 coussins tissu coloris éléphant 553/14 (sur demande, il est possible d'avoir un coussin de dossier de 50x46 cm à utiliser comme un coussin de dossier d'angle).









Divano Eagle 220 cm in pelle taupe
conan 51020 cat.4.

*Eagle sofa 220 cm leather taupe
conan 51020 cat.4*

Sofa Eagle 220cm Leder taupe
conan 51020 Kat.4.

*Canapé Eagle de 220 cm en cuir
Conan coloris taupe 51020 cat.4.*



02 / SOFAS / EAGLE

I rulli appoggiatesta sono indipendenti dallo schienale e sono amovibili facilmente dalla struttura (fissati con velcro internamente).

The back roll cushions are independent from the back cushion and are easily removable by the structure (fixed with velcro internally).

Die Rückenrollen sind unabhängig von den Rückenkissen und lassen sich herausnehmen (intern sind diese mit Klettband befestigt).

Les rouleaux appui-têtes sont indépendants des coussins des dossiers et sont facilement démontables de la structure (fixés avec velcro interne).



Zoe

design Studio Tecnico Gyform

Minimalismo deluxe e purezza formale, eleganza e preziosi particolari. Un divano esclusivo che si distingue per la cura del dettaglio nelle cuciture raffinate e preziose. Cuscini schienale reclinabili in due posizioni per il massimo comfort.

Deluxe minimalism and purity of form, with elegance and fine details. A stylish sofa that stands out for its attention to detail in the refined seams. Back cushions reclining in two positions for maximum comfort.

Eine exklusive Sofa, das sich durch seine Liebe zum Detail sowie raffinierten Nähten und den bequemen und verstellbaren Rückenissen auszeichnet. Maximaler Komfort ist hier die Maxime.

Minimalisme et luxe, pureté formelle et élégance avec des détails raffinés. Un canapé-exclusif qui se distingue par son sens du détail dans les coutures travaillées. Coussins dossier inclinable en deux positions pour un maximum de confort.









Terminale 192 cm destro e chaise
longue 220x120 cm sinistra in pelle
Conan ghiaccio 51045 cat.4 con
piedini in alluminio lucido.

*Right arm facing sofa 192 cm and
left arm chaise longue 220x120 cm in
white leather Conan 51045 cat.4 with
legs aluminium polished.*

Endelement 192 cm rechts und
Liege 220x120 cm links im Leder
Conan weiss 51045 Kat.4 mit Fuß
Alu poliert.

*Terminal droite 192 cm et chaise
longue gauche 220x120 cm en cuir
blanc Conan 51045 cat.4 avec pieds
en aluminium brillant.*



Dettaglio cuscino schienale trapuntato.

Detail back cushions quilted.

Detail Rückenkissen gesteppt.

Détail coussin dossier capitonné.





Terminale 192 cm sinistro e angolo terminale 220x100 cm destro in pelle antracite con cuscini schienale trapuntati e piedini metallo con finitura Nickel.

Left arm facing terminal 192 cm and right corner terminal 220x100 cm in leather anthracite with back cushions quilted and legs in black Nickel-plated metal.

Endelement 192 cm links und Liege 220x100 cm rechts im Leder dunkel grau Rückenissen gesteppt. Füße Metallplatte Nickel schwarz.

Terminal gauche 192 cm et angle terminal droit 220x100 cm en cuir antracite avec coussins dossiers capitonnés et pieds en métal noir Nickel.

02 / SOFAS / ZOE

Divano Zoe 240 cm con 2 cuscinetti
47x47 cm in pelle bianca Breezzer con
cuscini schienale lisci.

*Sofa Zoe 240 cm with 2 loose pillows
47x47 cm in white leather Breezzer with
back cushions without seams.*

Sofa Zoe 240 cm mit 2 losen Kissen
47x47 cm in Leder weiss Breezzer,
Rückenkissen ohne Steppung.

*Canapé Zoe 240 cm avec 2 coussins
47x47 cm en cuir blanc Breezzer avec
coussins dossiers lisses.*





Longisland

design Studio Tecnico Gyform

Accogliente, raffinato ed informale al tempo stesso. Un sistema che permette di disegnare differenti soluzioni compositive, oltre a consentire la scelta tra due diverse tipologie di base: i piedini in legno o il tubolare in alluminio lucido.

Cozy, refined and informal at the same time. A system that allows you to create different compositions, as well as offering the choice between two different types of bases: wood feet or polished aluminum tubes.

Gemütlich, raffiniert und typisch italienisch zugleich. Ein System, mit dem Sie verschiedene Kompositionen realisieren. Sie haben die Wahl zwischen verschiedenen Fusselementen und gestalten somit Ihr individuelles Möbel.

Confortable, raffiné et informel dans le même temps. Un système qui vous permet de créer des compositions différentes, ainsi que de permettre le choix entre deux types différents de la base: les pieds dans le tube de bois ou en aluminium poli.









Divano 250 cm in tessuto polly sabbia 552/05 cat.E con 2 cuscini schienale con rullo da 80x60 cm e piedini Honolulu in legno finitura wengè.

Sofa 250 cm in fabric polly sand 552/05 cat.E with 2 cushions with roll 80x60 cm and legs Honolulu in wood finishing wengè.

Sofa 250 cm in Stoff polly sand 552/05 Kat.E und 2 Kissen mit Rolle 80x60 cm. Füße Honolulu in Holz, Ausführung wengè.

Canapé 250 cm en tissu polly sabbia 552/05 cat.E et 2 coussins avec rouleau 80x60 cm; pieds Honolulu en bois wengè.



Dettaglio cuscinetto con rullo 50x58 cm;
piedino Honolulu in legno finitura wengè.

*Detail of cushion with roll 50x58 cm;
leg Honolulu in wood finishing wengè.*

Detail vom Kissen mit Rolle 50x58 cm;
FüÙe Honolulu in Holz Ausführung wengè.

*Détail du coussin avec rouleau 50x58 cm;
pied Honolulu en bois wengè.*



02 / SOFAS / LONGISLAND

Terminale 225 cm con 2 cuscini schienale con rullo da 80x60 cm ed angolare 143x143 cm con 3 cuscineti 60x60 cm in tessuto 100% lino Ecolino 551/03 cat.E; base tubolare in alluminio lucido.

Terminal 225 cm with 2 cushions with roll 80x60 cm and corner element 143x143 cm with 3 cushions 60x60 cm in fabric 100% linen Ecolino 551/03 cat.E; tubular base in polished aluminium.

Endelement 225 cm und 2 Kissen mit Rolle 80x60 cm plus Eckenelement 143x143 cm mit 3 Kissen 60x60 cm in Stoff, 100% Leinen Ecolino 551/03 Kat.E. FüÙe, durchgehendes Gestell Aluminium poliert.

Terminal 225 cm avec 2 coussins dossier avec rouleau 80x60 cm et Angle carré 143x143 cm avec 3 coussins 60x60 cm en tissu 100% lin "Ecolino" 551/03 cat.E; base tubulaire aluminium luisant.





Broadway

design Studio Tecnico Gyform

Volumi geometrici imbottiti ricreano un equilibrio tra tradizione e modernità. Elegante e altamente confortevole, mediante un semplice gesto permette di variare l'altezza degli schienali, reclinabili in due posizioni.

Geometric padded shapes recreate a balance between tradition and modernism. Elegant and highly comfortable, with a simple form allows you to vary the height of the backrests, reclining in two positions.

Zwischenn Tradition und Moderne. Elegant und sehr komfortabel, mit einer einfachen Mechanik können Sie die Höhe der Rückenlehnen in zwei Positionen variieren. Auf Wunsch ist auch der Sitz ausziehbar.

Volumes géométriques rembourrés recréent un équilibre entre tradition et modernité. Élégant et très confortable, avec d' un geste simple permet de faire varier la hauteur des dossiers inclinables en deux positions.









Divano 232 cm in pelle grigia Ibiza 82380
cat.4 con seduta relax (optional).

*Sofa 232 cm in leather grey Ibiza 82380
cat.4 with relax seat system (optional).*

Sofa 232 cm in Leder grau Ibiza 82380
Kat.4 mit Sitzauszug (optional).

*Canapé 232 cm en cuir Ibiza gris 82380
cat.4 avec assise relax (option).*

02 / SOFAS / **BROADWAY**

Dettaglio seduta relax estraibile fino a 22 cm (optional), meccanismo schienale e piedino cromato.

Detail of backrest adjustable in two positions, seat that can be pulled out up to 22 cm (optional) and chrome legs.

Detail vom Rückenkissen verstellbar und Sitzkissen mittels Mechanismus für Relaxposition bis 22 cm nach vorne ausziehbar (optional). Detail vom Chrom Fuß.

Détail d'assise relax réglable jusqu'à 22 cm (option), dossier relevable avec mécanisme; piétement aluminium brillant.









Terminale 186 cm destro e chaise longue
230x100 cm sinistra in pelle bianca
Breezzer 41045 cat.3 con 1 cuscinetto con
rullo 58x50 cm.

*Right arm facing sofa 186 cm and left arm
chaise longue 230x100 cm in leather white
Breezzer 41045 cat.3 with one cushion with
roll 58x50 cm.*

Endelement rechts 186 cm und Liege
links 230x100 cm in Leder weiß Breezzer
41045 Kat.3 plus 1 Kissen mit Rolle 58x50
cm.

*Terminal droit 186 cm et chaise longue
gauche 230x100 cm en cuir blanc
Breezzer 41045 cat.3 avec 1 coussin
avec rouleau 58x50 cm.*





Dettaglio cuscinetto con rullo da utilizzare come cuscino schienale su bracciolo chaise longue.

Detail of cushion with roll to use as back cushion on the arm of the chaise.

Detail vom Kissen. Kann Verwendung als Rückenkissen beim Armteil der Liege finden.

Détail du coussin avec rouleau à utiliser comme coussin de dossier sur l'accoudoir de la chaise longue.

Nano

design Studio Tecnico Gyform

Una nuova espressione del comfort rappresentata in una seduta unica, priva di base, disponibile in tre diverse dimensioni. Un divano dotato di una spiccata personalità, al quale si accostano armoniosamente anche la poltrona ed il pouf.

A new expression of comfort represented in a single section without a base, available in three different sizes. A sofa with a distinct personality, which harmoniously combines with the chair and ottoman.

Ein neuer Ausdruck von Komfort, ohne Sockel, in drei verschiedenen Größen. Ein Sofa mit ganz eigenem Charakter und Designanspruch das sich harmonisch in ihr Umfeld einpasst und doch aufgrund seiner unkonventionellen Art provoziert.

Une nouvelle expression de confort représentée avec une assise d'un seul tenant, sans base, disponible en trois tailles différentes. Un canapé avec une personnalité distincte, auquel ont peut assortir le fauteuil et le pouf.









Poltrona senza braccioli Nano e pouf
75x75 cm in pelle toledo topo 02 cat.5
versione trapuntata.

*Armless chair and ottoman 75x75 cm
Nano in Leather toledo taupe 02 cat.5
quilted version.*

Sessel Nano ohne Armteil mit Hocker
75x75 cm in Leder Toledo taupe 02 Kat.5;
gesteppte Ausfuehrung.

*Fauteuil sans accoudoir et pouf 75x75
cm Nano en cuir taupe Toledo 02 cat.5
version piqué.*



02 / SOFAS / NANO

Divano Nano 240 cm in tessuto mistolino clou 557/03 cat.E con cuscinetti in tessuto riga larga 437/03 cat.D e riga 438/03 cat.D e pouf 75x75 cm in pelle toledo topo 02 cat.5 con ripiano trapuntato.

Sofa Nano 240 cm in fabric linen 557/03 cat.E with loose pillows fabric wide stripe 437/03 cat.D and stripe 438/03 cat.D; ottoman 75x75 cm in leather toledo taupe 02 cat.5 with top quilted.

Nano Sofa 240 cm in Stoff Leinen 557/03 Kat.E mit losen Wurfkissen Kissen; Stoff mit breiten Streifen 437/03 Kat.D und Streifen 438/03 Kat.D; Hocker 75x75 cm in Leder Toledo taupe 02 Kat.5 mit Top gesteppt.

Canapé Nano 240 cm en tissu en lin 557/03 cat.E et coissins oreilles en tissu 437/03 et 438/03 cat.D; pouf en cuir 75x75 cm toledo taupe 02 cat.5 avec le dessus matelassé.



Athos

design Studio Tecnico Gyform

Forme abbondanti che si fondono con un design pulito ed una flessibilità funzionale attraverso la seduta estraibile in quattro diverse posizioni: sedendosi e spingendo anteriormente il sedile, è possibile scegliere la posizione desiderata ed ottenere l'effetto relax.

Abundant forms that blend with a clean design and functional flexibility. The adjustable seat has four different positions: sitting and pushing the front seat, it's possible to choose the desired position and obtain the relaxing effect.

Opulente Formen, die mit einem klaren Design und hoher Funktionalität überzeugen. Hohe Flexibilität durch einen in vier verschiedenen Positionen einstellbaren Sitz. Nutzen Sie die hohe Flexibilität und machen es sich gemütlich.

Formes généreuses qui s'harmonisent avec un design épuré et une flexibilité fonctionnelle à travers le siège amovible dans quatre positions différentes: assis et en poussant le siège avant, vous pouvez choisir l'emplacement que vous désirez et obtenir un effet relaxant.







1.



2.



1. Divano Athos 248 cm in tessuto melange bianco nero 407/58 cat.D con piedini ovali in alluminio lucido.
2. Dettaglio seduta relax nelle varie posizioni.

1. Sofa Athos 248 cm in fabric melange black & white 407/58 cat.D with oval legs aluminium polished.
2. Detail of adjustable seat cushions in different positions.

1. Sofa Athos 248 cm im Stoff melange weiß und schwarz 407/58 Kat.D mit Füßen oval Alu poliert.
2. Detail Sitzkissen verstellbar in verschiedene Positionen.

1. Canapé Athos 248 cm en tissu melange blanc et noir 407/58 cat.D avec pieds ovales en aluminium brillant.
2. Détail coussin d'assise avec relax.

3. Divano Athos 248 cm in pelle antracite conan 51010 cat.4 con base laccata nera.

3. Sofa Athos 248 cm in leather conan 51010 cat.4 with lacquered black base.

3. Sofa Athos 248 cm in Leder dunkel grau conan 51010 Kat.4 mit Sockel schwarz lackiert.

3. Canapé Athos 248 cm en cuir antracite conan 51010 cat.4 avec base en bois noir.



3.



2.



1.



Athos Mini

design Studio Tecnico Gyform

1. Due poltroncine Athos Mini in pelle antracite Conan 51010 cat.4.
2. Dettaglio piedino ovale in alluminio lucido.

*1. Two armchairs Athos Mini in leather Conan 51010 cat.4.
2. Detail oval legs aluminium polished.*

1. Zwei sessel Athos Mini im Leader dunkel grau Conan 51010 Kat.4.
2. Detail FüÙe oval Alu poliert.

*1. Deux petits fauteuils Athos Mini en cuir antracite Conan 51010 cat.4.
2. D tail pied oval en aluminium brillant.*



Domino

design Studio Tecnico Gyform

Linee pulite, armonia e discrezione per un sistema di sedute capace di adattarsi in ogni ambiente. Disponibile in due diverse profondità, con un'ampia gamma compositiva che comprende elementi lineari, angolari, chaise longue e pouf, Domino offre l'interpretazione più classica del comfort.

Clean lines, harmony and discretion for a seating system that can adapt to any environment. Available in two different depths, with a wide range of compositions comprising linear elements, corner, chaise lounge and ottoman. Domino offers the most classic interpretation of comfort.

Klare Linien, Harmonie und Zurückhaltung für ein Sitzsystem das sich jeder Umgebung anpasst. Erhältlich in zwei verschiedenen Tiefen, mit einer breiten Palette an verschiedenen Elementen, und Sofa bietet Domino eine klassische Interpretation von Komfort.

Des lignes épurées, l'harmonie et la discrétion d'un système de sièges qui peuvent s'adapter à tout environnement. Disponible en deux profondeurs différentes, avec une large gamme de composition comprenant des éléments linéaires, coin, une chaise longue et pouf, Domino offre l'interprétation la plus classique de confort.











Egoista

design Studio Tecnico Gyform

Volumi contenuti ed aggraziati, con un effetto visivo di grande leggerezza. Proporzioni calibrate ed un equilibrio dato dalle forme semplici, pulite ed eleganti nella loro linearità, spoglie di ogni apparato decorativo all'insegna della funzione.

Low profile and graceful, with a visual effect of lightness. Calibrated proportions and balanced with simple forms, clean and elegant in their lines, without any decorations in the name of function.

Geringer Lautstärke und anmutig, mit einem visuellen Effekt von großer Leichtigkeit. Kalibriert Proportionen und Abgleichdaten bei einfach, sauber und elegant in ihrer Linearität, nackten jeder dekorativen Banner der Funktion.

Faibles volumes et gracieuse, avec un effet visuel d'une grande légèreté. Les proportions et les données de balance calibrée avec simple, propre et élégant dans leur linéarité, nue de toute bannière décorative de la fonction.





02 / SOFAS / EGOISTA

Divano 250x90 cm in pelle pieno fiore Conan nero 51014 cat.4 con 2 cuscinetti schienale 65x65 cm con cuciture a scacchi + 3 cuscinetti 55x55 cm.

Sofa 250x90 cm in top grain leather black Conan 51014 cat.4 with 2 loose cushions 65x65 cm with square stitching and 3 cushions 55x55 cm.

Sofa 250x90 cm im vollnarbigen Leder schwarz Conan 51014 Kat.4 mit 2 losen Kissen 65x65 cm mit Ziernähten und 3 Kissen 55x55 cm.

Canapé 250x90 cm en cuir pleine fleur Conan noir 51014 cat.4 avec 2 coussins oreillers 65x65 cm avec coutures en damiers + 3 coussins 55x55 cm.





Terminale 155x103 cm destro e chaise longue 160x125 cm sinistra in tessuto bianco 541/02 cat.E con 2 cuscinetti 65x65 cm, 3 cuscinetti 55x55 cm e 2 cuscinetti 45x45 cm.

Right arm terminal 155x103 cm and left chaise longue 160x125 cm in fabric white 541/02 cat.E with 2 loose pillows 65x65 cm, 3 pillows 55x55 cm and 2 pillows 45x45 cm.

Endelement 155x103 cm rechts und Liege 160x125 links in Stoff weiß 541/02 Kat.E mit 2 losen Kissen 65x65 cm, 3 Kissen 55x55 cm und 2 Kissen 45x45 cm.

Terminal droit 155x103 cm et chaise longue gauche 160x125 cm en tissu blanc 541/02 cat.E avec 2 coussins 65x65 cm, 3 coussins 55x55 cm et 2 coussins 45x45 cm.



Big Ben

design Studio Tecnico Gyform

I volumi abbondanti incontrano il rigore formale, donando eleganza e ricercatezza per un prodotto "senza tempo". Disponibile sia nella versione divano che poltrona, Big Ben risulta indicato anche per il mondo contract, hall e spazi comuni in genere.

Abundant shapes meet rigorous form, giving elegance and refinement for a "timeless" product. Available in both sofa and armchair, Big Ben is particularly suitable for the contract world, ideal in lobbies and common areas in general.

Maskuline Form, starke Präsenz, "zeitlos" Erhältlich als Sofa und Sessel, ist Big Ben optimal geeignet für den Wohnraum zuhause als auch für Objekte und die Hotelloobby.

Volumes agréables et t forme rigoureuse, donnant une impression d'élégance et de raffinement pour un produit "intemporel". Disponible en canapé et un fauteuil, Big Ben est adapté aussi pour le monde du business, les halls et les espaces publics.



02 / SOFAS / **BIG BEN**

Divano 240 cm in pelle conan 51006
cat.4 con piedi wengè e pouf 60x60 cm
in mucca tricolore 70301 cat.6.

*Sofa 240 cm in leather conan 51006
cat.4 with wengè legs and footstool 60x60
cm in cow skin 70301 cat.6.*

Sofa 240 cm in Leder dunkel braun conan
51006 Kat.4 mit Füße wengè gebeizt und
Höcker 60x60 cm in Kuhfell 70301 Kat.6.

*Canapé 240 cm en cuir marron foncé
conan 51006 cat.4 avec piétement bois
teinté wengé et pouf 60x60 cm en cuir de
vachette marron et blanc 70301 cat.6.*





Composit

design Studio Tecnico Gyform

Una proposta che si adatta perfettamente a diversi tipi di ambienti. Disponibile la versione con tubo poggiatesta in legno o acciaio, oppure la versione con rulli regolabili. Composit "A" con piedino a placca in acciaio o legno; Composit "B" ed elementi senza braccioli con piedini cilindrici alti 10 cm in legno o acciaio.

A design that adapts perfectly to different types of environments. Available in version with tube headrest in wood or steel, or the version with adjustable rollers. Composit "A" with a base plate in steel or wood; Composit "B" without arms with cylindrical feet 10 cm high in wood or steel.

Ein Sofa, das sich perfekt auf verschiedene Umgebungen anpasst. Verfügbare Ausführung mit Reling in Holz oder Stahl, oder als Version mit einstellbaren Rollen. Composit "A" mit einer Fussplatte in Stahl oder Holz; Composit "B" mit zylindrischem Fuß 10 cm hoch in Holz oder Stahl.

Une proposition qui s'adapte parfaitement à différents types d'environnement. Disponible en version avec tube appuie-tête en bois ou en acier, ou la version avec rouleaux appuie-tête réglables. Composit "A" avec une plaque de pression en acier ou en bois; Composit "B" et sans armes avec pieds cylindriques de hauteur 10 cm en bois ou en acier.

COMPOSIT A



COMPOSIT B





Dettaglio tubo poggiatesta e rulli regolabili.

Detail of headrest tube and roll headrest adjustable.



Detail vom schwebende Relling und Rückenrolle vierfach verstellbar.

Détail de barre appuie-tête et barres réglables revêtues de tissu.

02 / SOFAS / COMPOSIT

Angolo terminale 200x85 cm e terminale destro da 173 cm Composit B con piedini in acciaio e tubo poggiatesta su bracciolo lungo in legno tinto wengè.
Rulli regolabili rivestiti in tessuto per tutti gli schienali.

*Corner terminal 200x85 cm and one arm loveseat 173 cm Composit B with steel legs and headrest tube on chaise in wood wengè finishing.
Roll headrest adjustable for a better support for all the back cushions.*

Liege 200x85 cm links und Endelement 173 cm rechts Composit B mit Edelstahl Stelzfüsse und schwebende Relling aus Holz Farbe wengè.
Rückenrolle vierfach verstellbar für alle Rückenkissen.

*Angle terminal de 200x85 cm et terminal droit de 173 cm avec des pieds en acier et barre appuie-tête sur l'accoudoir long en bois teinté wengé.
Barres réglables revêtues de tissu pour tous les dossiers.*



Doge

design Studio Tecnico Gyform

Doge risponde al desiderio di massimo comfort, morbidezza ed informalità, unito ad un design adatto anche ai contesti più classici. Ciascuna seduta è estraibile e gli schienali sono reclinabili in quattro diverse posizioni.

Doge is the answer to the desire for comfort, softness and informality, combined with a design suitable in more classical settings. Each seat can be adjusted and the seat backs can be reclined in four different positions.

Doge ist eine Reaktion auf den Wunsch nach Komfort, Weichheit und Ungezwungenheit in Verbindung mit einem traditionellen Design. Jeder Sitz kannausgezogen, und die Sitzlehne kann in vier verschiedenen Positionen verstellt werden.

Doge répond au désir de confort, de douceur et de l'informalité, offre un design adapté à des contextes plus traditionnels. Chaque assise relax peut coulisser independamment et les dossiers de siège peuvent être inclinés dans quatre positions différentes.



Composizione ad angolo Doge (2 terminali 162 cm e angolo quadro 122x122 cm) in microfibra like suede lichene 4004/181 cat.C con sedute estraibili e schienale reclinabile in 4 posizioni.

Composition Doge (2 terminals 162 cm and square corner 122x122 cm) in microfiber likesuede lichen 4004/181 cat.C with adjustable seats and back cushions reclining in 4 positions.

Eckegruppe Doge (2 Endelemente 162 cm und rechtwinklige Ecke 122x122 cm) in Mikrofaser likesuede lichene 4004/181 Kat.C mit verstellbaren Sitzen und Rückenissen verstellbar in 4 Positionen.

Composition Doge (2 terminal 162 cm et angle carré 122x122 cm) en microfibre likesuede lichen cat.C 4004/181 avec des sièges réglables et coussins de dossier inclinable en 4 positions.





Mito A

design Studio Tecnico Gyform

Un divano confortevole e discreto che amalgama reminiscenze classiche e tendenze contemporanee. Si distingue per le forme morbide e curve dei suoi braccioli, che offrono un'interpretazione contemporanea di un'eleganza retrò.

A comfortable and discrete sofa that combines classical reminiscences and contemporary trends. It is distinguished by the soft lines and curves of its arms, offering a modern interpretation of retro elegance.

Einfach nur bequem, an zeitgenössische Trend erinnernd. Geprägt von den weichen Linien und Kurven Man muss es live erleben. Ein Klassiker der Kollektion, über Jahre weiter entwickelt, hat sich als fester Bestandteil etabliert.

Un canapé confortable et discret qui fusionne réminiscences classiques et tendances contemporaines. Il se distingue par des lignes douces et courbes de ses bras, offrant une interprétation contemporaine de l'élégance rétro.





Divano 248 cm in tessuto gessato corda 345/03 con 2 cuscinetti in mistolino unito 348/03.

Sofa 248 cm in fabric gessato corda 345/03 with 2 loose pillows mistolino unito 348/03.

Sofa 248 cm im Stoff gessato corda 345/03 mit 2 lose Kissen mistolino unito 348/03.

Canapé 248 cm en tissu gessato corda 345/03 avec 2 coussins en mistolino unito 348/03.

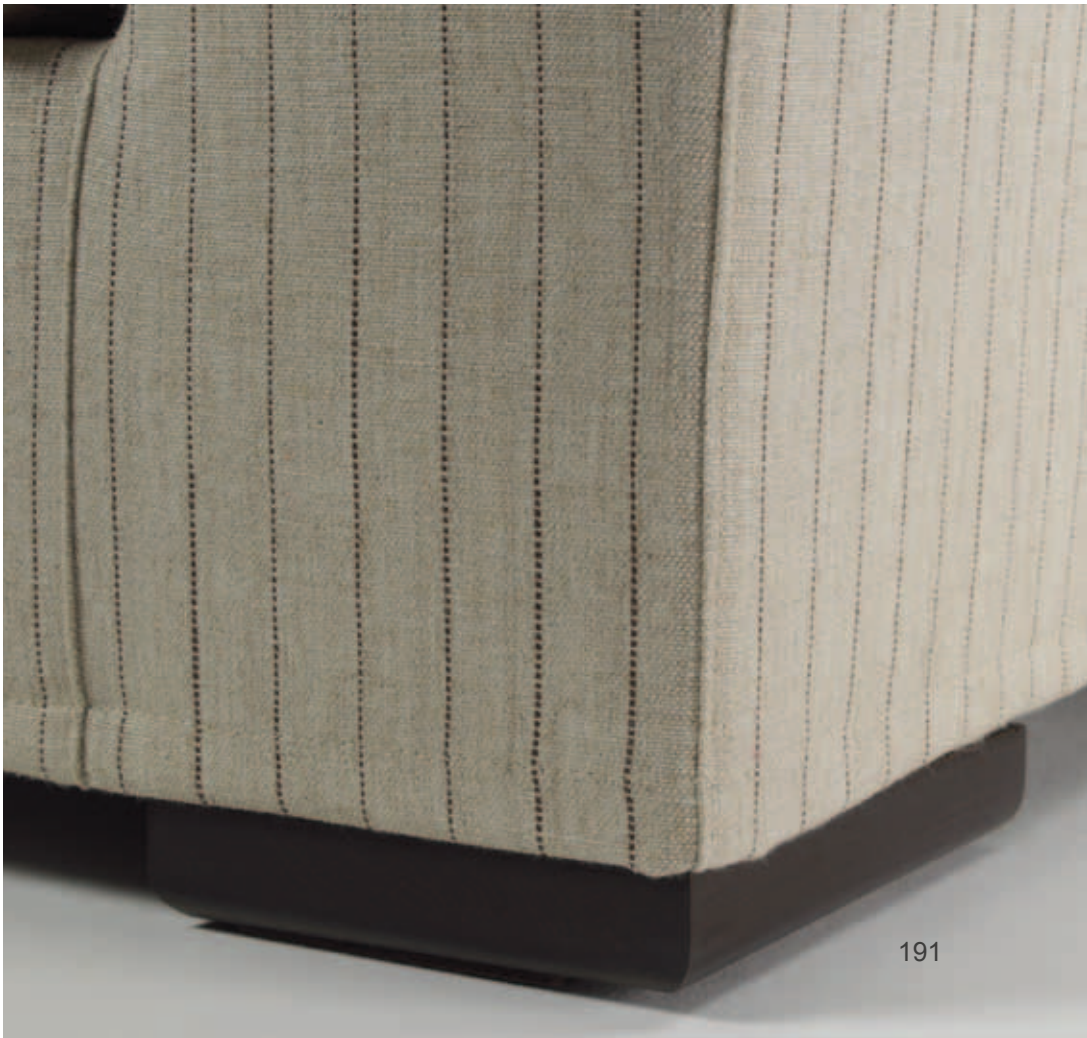

Mixer New

design Studio Tecnico Gyform

Volumi geometrici imbottiti e soffici, sovrapposti da essenziali piedini a lama, in alluminio satinato. Per un maggiore comfort è previsto un rullo poggiatesta che può essere facilmente posizionato in prossimità dello schienale.

Geometric shapes softly upholstered, supported by blade feet in brushed aluminum. Additional comfort is provided by a roller headrest that can be easily positioned on the backrest.

Geometrische Form, Füße aus gebürstetem Aluminium. Zusätzlicher Komfort kann mit einer Kopfstütze in Rollenform realisiert werden.

Volumes géométriques couettes et moelleux, recouvertes par ldes pieds en forme de lame essentiellement en aluminium brossé. Pour plus de confort il est prévu un repose-tête amovible qui peut être facilement positionné à proximité du dossier.



Terminale Mixer 193 cm sinistro e chaise longue 162x93 cm destra con 2 cuscini 47x47 cm e rullo poggiatesta. Piedino Lama a "L" in alluminio satinato.

Left arm facing sofa 193 cm and right arm chaise longue 162x93 cm with 2 loose cushions 47x47 cm and roll headrest. Legs Lama "L" aluminium mat.

Endelement 193 cm links und Liege 162x93 cm rechts mit 2 Kissen 47x47 cm und Rolle Kopfstütze. Füße Lama "L" Form aus Alu gebürstet.

Terminal gauche 193 cm et chaise longue droit 162x93 cm avec 2 petit coussins 47x47 cm et un appuie-tête rouleau. Piedes Lama "L" aluminium satiné.



Dettaglio del rullo poggiatesta.

Detail Rolle Kopfstütze.

Detail of roll headrest.

Detail de l'appuie-tête rouleau.



Mixer Mini

design Studio Tecnico Gyform

Poltroncina dal design lineare ed essenziale, è l'ideale sia per progetti di tipo residenziale che per spazi pubblici quali reception, hall, lounge e gallerie.

Armchair with linear and clean design, ideal for residential projects as well as public spaces such as reception areas, lobbies, lounges and galleries.

Sessel in geradlinigem Design und reduziert auf das wesentliche, ideal für Wohnprojekte, für öffentliche Räume wie Rezeption, Lobby, Lounge und Galerien.

Fauteuil design linéaire et essentielle, est idéal pour des projets résidentiels pour les espaces publics tels que la réception, le hall, un salon et des galeries.





Piccola ma graziosa per un design senza tempo: Mixer Mini è l'espressione dello stile minimalista. La sua attrattività si basa sul contrasto tra la sottile e geometrica struttura ed il comodo volume dei cuscini di seduta e schienale.

Small but graceful for a timeless design: Mixer Mini is an expression of the minimalist style. Its attractiveness lies in the contrast between the delicate, geometric structure and the comfortable size of the seat and back cushions.

Klein aber fein mit zeitlosem Design: der neue Entwurf Mixer Mini ist von einem besonderes grazilen Esprit geprägt, minimaler geht es nicht mehr. Seine Attraktivität beruht dem Gegensatz zwischen der grazilen, geometrischen Struktur und dem sehr bequemen Volumen der Sitz und Rücken kissen.

Petit mais gracieux pour un design intemporel. Le Mixer Mini est l'expression d'un style minimaliste. Tout son attrait est basé sur le contraste entre la finesse et la géométrie de sa structure, et sur le confort de ses coussins d'assise et de dossier.

03.

LETTI
BEDS

Plan letto

design Studio Tecnico Gyform

Le valenze progettuali e le caratteristiche estetiche del divano Plan si estendono anche all'omonimo letto. Il disegno essenziale e l'equilibrio dei volumi si sposano con la funzione, attraverso i cuscini schienale reclinabili in due posizioni.

The design and characteristics of the Plan sofa also extend to the Plan bed. The minimalistic design and balance of shapes combine with function, with the back cushions in two reclining positions.

Angelehnt an das Design der Sofa Linie Plan entstand diese exklusive Betten-Design. Design kombiniert mit Funktion, das ist hier die Aussage.

La conception et l'apparence du canapé plan s' étendent également au lit. La conception et l'équilibre des volumes essentiels sont combinés avec la fonction, à travers les coussins de dos en deux positions d'inclinaison.







03 / BEDS / PLAN LETTO B

1. Letto Plan "B" in pelle antracite con piedi in metallo finitura Nickel nero.

1. Bed Plan "B" in leather antracite with legs in black Nickel-plated metal.

1. Bett Plan "B" in Leder dunkel grau, Füße Nickel schwarz.

1. Lit Plan "B" en cuir gris foncé avec pieds en métal noir Nickel.

2. Dettaglio cuscino schienale reclinabile in posizione alta.

2. Detail of backrest adjustable in the high position.

2. Detail höchste Position vom Rückenkissen verstellbar.

2. Détail coussin dossier inclinable en position haute.

1.



2.



3.



3. Dettaglio cuscino schienale
reclinabile in posizione bassa.

*3. Detail of backrest adjustable
in the low position.*

3. Detail niedrigste Position vom
Rückenkissen verstellbar.

*3. Détail coussin dossier inclinable
en position basse.*



03 / BEDS / PLAN LETTO A

1.

1. Letto Plan "A" 190x250 cm in pelle conan burro con piedi in metallo con finitura Nickel nero.

1. Bed Plan "A" 190x250 cm in leather conan butter with legs in black Nickel-plated metal.

1. Bett Plan "A" 190x250 cm in Leder butter Füße Nickel schwarz.

1. Lit Plan "A" 190x250 cm en cuir burro Conan avec pieds en métal noir Nickel.



2.





2. Dettaglio diverse posizioni cuscini schienale.

2. *Detail of backrest adjustable in two positions.*

2. Detail Positionen vom Rückenissen verstellbar.

2. *Détail coussin dossier réglable.*

04.

POLTRONCINE
ARMCHAIRS

Chanel

design Studio Tecnico Gyform

Una seduta che sintetizza i concetti di semplicità ed eleganza, caratterizzata dalle linee curve e sinuose che ne evidenziano il design. Nell'immagine a destra, 2 poltroncine Chanel in velluto acquamarina 363/40 cat.C con piedi wenge'.

A chair which portrays the concepts of simplicity and elegance, characterized by curved lines that highlight the design. On the next page, 2 Chanel armchairs velvet Acquamarina 363/40 cat.C; wenge legs.

Eine Zusammenfassung der Konzepte von Einfachheit und Eleganz, gekennzeichnet durch geschwungene Linien, die das besondere Design hervorzuheben. Auf der rechten Seite, 2 Sessel Chanel Velour acquamarina 363/40 Kat.C; Fusse Wenge'.

Une assise résumant les concepts de simplicité et d'élégance, caractérisé par des lignes courbes et sinueuses qui mettent en valeur le design. Sur la page opposée, 2 fauteuils Chanel velour acquamarina 363/40 cat.C; pieds hêtre teinte wenge'.



Sophie

design Studio Tecnico Gyform

Una proposta dal volume leggero, la linea raffinata ed una forma avvolgente di estrema eleganza. Grazie alle sue dimensioni contenute può essere agevolmente inserita anche in ambienti di dimensioni ridotte. Nell'immagine a destra, 2 poltroncine Sophie in pelle Linea asfalto 660 cat.4 con piedi wengè.

A design of graceful shapes, with refined lines and an enveloping fit of pure elegance. Thanks to its compact frame, it can easily fit even in smaller spaces. On the next page, 2 Sophie armchairs leather Linea Asfalto 660 cat.4 with wenge legs.

Eine raffinierte Linie und eine perfekte Passform mit extremer Eleganz. Dank seiner geringen Größe können die Sessel leicht auch in kleineren Umgebungen eingesetzt werden. Auf der rechten Seite, 2 Sessel Sophie Leder Linea asfalto 660 Kat.4; Fusse Wengè.

Une proposition de légèreté, la ligne raffinée et un ajustement parfait de l'extrême élégance. Grâce à son faible encombrement, il peut être facilement intégré, même dans des environnements plus petits. Sur la page opposée, 2 fauteuils Sophie cuir Linea asfalto 660 cat.4; pieds hêtre teinte wenge'.



Gaia

design Studio Tecnico Gyform

Una seduta di ampie proporzioni, linee morbide e spiccata personalità per una poltroncina che diviene un moderno elemento d'arredo dal carattere versatile. Nell'immagine a destra, poltroncina Gaia in velluto azzurro e base wenge'.

A seat of ample proportions, soft lines and distinctive personality for a chair that becomes a modern element of furniture from its versatile character. On the next page, Gaia armchair in Light Blue velvet with wenge base.

Ein Sitz mit ausgewogenen Proportionen, glatte Linien und eine starke Persönlichkeit. Ein Stuhl mit eigenständiger Charakteristik. Auf der rechten Seite, Sessel Gaia Velour hell blu mit Basis Wenge'.

Un siège de confortable proportion, des lignes douces et une forte personnalité pour une chaise qui devient un meuble moderne au caractère polyvalent. Sur la page opposée, Fauteuil Gaia velour bleu clair avec base hêtre teinte wenge'.



Giò

design Studio Tecnico Gyform

Poltroncina Giò e cuscinetto 68x68 cm in tessuto melange acquamarina 440/40 cat.D. Piedi wenge'.

Armchair Giò and loose pillow 68x68 cm in fabric Melange Acquamarina 440/40 cat.D. Wengè legs.

Sessel Giò mit losem Kissen 68x68 cm in Stoff melange acquamarina 440/40 Kat.D. Fusse Wenge'.

Fauteuil Giò avec coussin 68x68 cm tissu melange acquamarina 440/40 cat.D. Pieds hêtre teinte wenge'.





Megane

design Studio Tecnico Gyform

Linee morbide e proporzioni misurate con chiari riferimenti alla tradizione sono rivistati in chiave contemporanea.

Soft lines and moderate proportions with clear references to tradition are revisited in a contemporary way.

Weiche Linien und Proportionen mit klaren Hinweisen auf Tradition sind in einer modernen Art und Weise interpretiert.

Des lignes douces et proportions agréables avec des références classiques à la tradition.





Poltroncina Megane velluto azzurro
363/43 cat.C con piedi laccati neri.

*Megane armchair Light Blue velvet
363/43 cat.C black lacquered legs.*

Sessel Megane Velour hell blau 363/43
Kat.C Füsse Holz schwarz.

*Fauteuil Megane velour azzurro 363/43
cat.C pied hêtre teinte noir.*

Chica

design Studio Tecnico Gyform

Il segno continuo di seduta e bracciolo caratterizza Chica, poltroncina girevole a 360°. Disponibile con schienale alto o basso, consente la scelta tra due tipologie di base: con piatto in acciaio inox oppure cromo lucido a razze.

The continuous line of seat and armrest characterize Chica, a 360° swivel chair. Available with high or low back, it offers a choice between two types of bases: flat plate in stainless steel or chrome spokes.

Klare, reduzierte Formensprache, 360° drehbar. Der allrounder unter den Stuhlessel. Erhältlich mit hohem oder niedrigem Rücken. Zur Auswahl stehen zwei Grundtypen: flach mit Edelstahl oder Chrom Speichen.

Chica, 360° fauteuil pivotant présente une ligne épurée entre le siège et l'accoudoir. Disponible avec dossier haut ou bas, permet un choix entre deux types de piétement: plat avec de l'acier ou de chrome rayons en acier inoxydable.







Poltrona Chica e pouf 40x60xH51 cm
in tessuto rigato 558/05 cat.E.

*Chica armchair and ottoman 40x60xH51
cm, ribbed fabric 558/05 cat.E.*

Chica Sessel und Hocker 40x60xH51 cm,
Stoffbezug 558/05 Kat.E.

*Chica fauteuil et pouf 40x60xH51 cm en
tissu côtelé 558/05 cat.E.*



04 / ARMCHAIRS / CHICA

Poltroncina "Chica" (schienale alto) in tessuto polly sabbia 552/05 cat.E con base girevole cromo lucido a razze.

Armchair "Chica" (high back) in fabric polly sand 552/05 cat.E with swivel base in polished chrome.

Sessel "Chica" (hoher Rücken) in Stoff polly sand 552/05 Kat.E. Fuß, Basis drehbar polierten Chromuntergestell.

Fauteuil "Chica" (dossier haut) en tissu polly sable 552/05 cat.E avec base tournante plat en acier inox.







Chica low

design Studio Tecnico Gyform

Poltroncina "Chica low" (schienale basso)
in tessuto polly sabbia 552/05 cat.E con
base girevole piatto in acciaio inox.

*Armchair "Chica low" (low back) in fabric
polly sand 552/05 cat.E with swivel base
plate in matte steel.*

Sessel "Chica low" (niedriger Rücken)
in Stoff polly sand 552/05 Kat.E. Basis
drehbar flach in Edelstahl matt.

*Fauteuil "Chica low" (dossier bas) en
tissu polly sable 552/05 cat.E avec base
tournante plat en acier inox.*

Butterfly

design Studio Tecnico Gyform

Una poltrona dalle linee avvolgenti e confortevoli, in grado di creare un connubio perfetto di eleganza e comfort. Il dettaglio delle cuciture lascia trasparire una confezione meticolosa che esprime tutti i valori di una consolidata maestria artigianale.

An armchair with enveloping and cozy lines, able to create a perfect combination of elegance and comfort. The careful detail of the stitching expresses all the values of skilled craftsmanship.

Ein Sessel weiche Linien und sehr komfortabel, eine perfekte Kombination aus Eleganz und Komfort zu. Die Details der Nähte zeigen eine sorgfältige Verarbeitung, die alle Werte der Handwerkskunst zum Ausdruck bringt.

Un fauteuil aux lignes enveloppantes et confortables, capable de créer une combinaison parfaite de l'élégance et de confort. Le détail de la couture révèle un emballage minutieux qui exprime toutes les valeurs d'un artisanat solide.





Poltrona Butterfly in pelle Toledo
marmotta 03 cat.5 con cuciture aperte.

*Butterfly armchair in leather Toledo
woodchuck 03 cat.5 with open seams.*

Sessel Butterfly in Leder Toledo
Waldmurmeltier 03 Kat.5 mit offenen
Nähten.

*Fauteuil Butterfly en cuir Toledo
marmotte 03 cat.5 avec des coutures
ouvertes.*





Venus

design Studio Tecnico Gyform

Una poltroncina che si distingue per il volume compatto ed un'innata eleganza, sottolineata dalla struttura in alluminio lucido o satinato. Grazie al suo design rigoroso, risulta ideale per arredare con eleganza anche aree comuni quali lounges o sale d'aspetto.

A chair that stands out for its compact shape and an innate elegance, emphasized by a polished or satin aluminum frame. Thanks to its precise design, it is ideal for decorating areas such as lounges or waiting rooms with sophistication.

Ein Sessel weiche Linien und sehr komfortabel, eine perfekte Kombination aus Eleganz und Komfort zu. Die Details der Nähte zeigen eine sorgfältige Verarbeitung, die alle Werte der Handwerkskunst zum Ausdruck bringt.

Une chaise qui se distingue par son volume compact et une élégance innée, mis en évidence par la structure en aluminium brillant ou satiné. Grâce à sa conception rigoureuse, il est idéal pour décorer avec élégance aussi bien des salons que des salles d'attente.





2 poltroncine Venus in pelle bianca
Breezzer 41045 cat.3 con piedini in
alluminio lucido.

*2 armchairs Venus in white leather
Breezzer 41045 cat.3 with polished
legs.*

2 Sessel Venus in weißem Leder
Breezzer 41045 Kat.3, Untergestell
Chrom poliert.

*2 fauteuils Venus en cuir blanc
Breezzer 41045 cat.3 avec pieds
polis.*



Bobo

design Studio Tecnico Gyform

Una poltrona dalle linee essenziali, che si distingue per lo schienale avvolgente che continua nella linea del bracciolo.

A chair with clean lines that is distinguished by a wrapping back that is a continuous shape of the armrests.

Ein Sessel mit klaren Linien. Durch die runde Form lässt sich ein einzigartiges Sitzen realisieren.

Une chaise aux lignes épurées, qui se distingue par l'arrondi qui se poursuit dans la ligne du bras.





2 poltroncine in pelle cavallino testa di moro senza cuscinetto schienale.

2 armchairs in leather dark brown horses without round back cushion.

2 Sessel im Leder Felldunkel braun ohne runde Rückenissen.

2 Fauteuils en cuir poulain marron foncé sans coussin dossier.

Poltroncina con cuscinetto schienale.

Armchair with round back cushion.

Sessel mit runde Rückenissen.

Fauteuil avec coussin dossier rond.

Enigma

design Studio Tecnico Gyform

Poltroncina con struttura esterna rivestita in pelle bovina con pelo bianco-nero 70358 cat.6 e resto in pelle nera Conan 51014 cat.4.

Armchair with outside frame in skin cow leather black & white 70358 cat.6; inside frame and cushion black Leder Conan 51014 cat.4.

Sessel mit Außenkorpus in Kuhfell schwarz-weiß 70358 Kat.6 und Innen im Leder Conan schwarz 51014 Kat.4.

Petit fauteuil avec structure externe revêtue de cuir de vachette "Mucca" blanc-noir 70358 cat.6 et le reste en cuir noir Conan 51014 cat.4.





Natalie

design Studio Tecnico Gyform

Linee morbide e sinuose disegnano i braccioli e lo schienale della poltroncina Natalie. Una seduta confortevole dalle linee aggraziate, in grado di trasferire un senso di lusso e raffinatezza.

Gentle sinuous lines draw the arms and back of the chair Natalie. A superbly comfortable seat with graceful lines, able to transmit a sense of luxury and sophistication.

Eleganz und eine eigenständige Linienführung. Ein hauch von Luxus mit perfekter Sitzergonomie. Erhältlich mit Rädern oder mit Aluminiumfüßen.

Lignes fluides lisses dessinent les bras et le dos de la chaise Natalie. Un siège confortable par les lignes gracieuses, capables de procurer un sentiment de luxe et de raffinement.



Poltroncina Natalie in pelle conan
testa di moro 51006 cat.4 con ruote.

*Chair Natalie with wheels in leather
conan dark brown 51006 cat.4.*

Sessel Natalie in Leder dunkelbraun;
Conan 51006 Kat. 4, mit Rollen.

*Fauteuil Natalie en cuir brun foncé
conan 51006 cat.4 avec des roulettes.*

Mix

design Studio Tecnico Gyform

Divanetto Mix da 134 cm in pelle nera
Conan 51014 con piedino in alluminio.

*Sofa Mix 134 cm in black leather Conan
51014 with Aluminium legs.*

Sofa Mix 134 cm in schwarzem Leder
Conan 51014 mit Aluminium Füßen.

*Canapé Mix 134 cm en cuir noir Conan
51014 avec pied en aluminium.*





Due poltroncine Mix in pelle rifinita all'anilina colore bianco latte Oasis 65045 con base girevole in acciaio lucido.

Two armchairs Mix leather pure aniline white Oasis 65045 with swivel base steel polished.

Zwei Sessel Mix im Leder rein Anilin Weiß Oasis 65045 mit drehbaren Gestell poliert.

Doux fauteuils Mix en cuir pure aniline blanche Oasis 65045 avec base tournement en acier luisant.

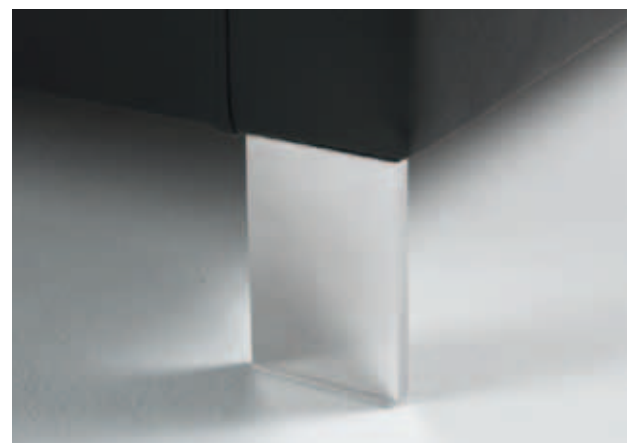

Queen

design Studio Tecnico Gyform

Poltroncina in pelle rifinita all'anilina Anilux testa di moro 61006 con piedi noce scuro.

Armchair in leather pure aniline dark brown Anilux 61006 with legs dark wood.

Sessel im Leder rein Anilin dunkel braun Anilux 61006 mit Füße Holz.

Fauteuil en cuir pure aniline marron fonce Anilux 61006 avec pieds en bois.







Clio

design Studio Tecnico Gyform

Una chaise-longue dall'impronta razionalista che coniuga un design essenziale e rigoroso con la funzione.

A chaise longue from the impression rationalist that combines a minimal design with a precise feature.

Eine Chaiselongue die auf einzigartige Weise ein minimalistisches Design mit Funktion verbindet.

Une chaise longue à la ligne sobre, épurée, qui combine un design minimal avec une fonction rigoureuse.

Possibilità di ottenere diverse inclinazioni sia dello schienale che del poggiatesta per ottenere il miglior comfort per qualsiasi occasione; con finitura trapuntata o liscia; come optional cuscinetto poggiatesta rettangolare o tondo.

Different back and footrest position to obtain the best comfort for all occasion; quilted or plain finishing; as optional back headrest pillow square or round.

Vielfach verstellbar dadurch optimal Position für relaxen, Schlafen oder Fernsehen; Ausführung gesteppt oder nicht; Kissen Kopfstütze quadratisch oder rund.

Possibilité d'obtenir différentes inclinaisons aussi bien pour l'assise que pour le dossier avec appui-tête afin d'obtenir un meilleur confort quelque soit l'occasion; avec finition matelassée ou tendu; en option coussin d'appui-tête rectangulaire ou demi rond.

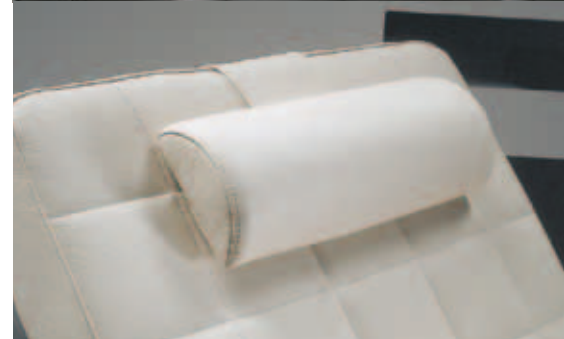

05.

COMPLEMENTI

COMPLEMENTS



Break

design Studio Tecnico Gyform

Tavolino Break 55x45xH52 cm con ripiano tinta wengè e struttura cromata e vassoio Loto 35x35 cm.

Table Break 55x45xH52 cm wengè finishing with chrome frame and tray Loto 35x35 cm.

Tisch Break 55x45xH52 cm wengè mit Gestell Metall verchromt und Tablett Loto 35x35 cm.

Petite table Break 55x45xH52 cm avec plateau couleur wengè et base mate et plateau Loto 35x35 cm.

Azalea Break

design Studio Tecnico Gyform

Tavolino Azalea Break 42x42xH67 cm,
struttura cromata.

*Table Azalea Break 42x42xH67 cm, with
chrome frame.*

Tisch Azalea Break 42x42xH67 cm,
mit Gestrell Metall verchromt.

*Petit table Azalea Break 42x42xH67 cm,
base mate.*



Molly

design Studio Technico Gyform

Pouf Molly 80x80 cm in cavallino caffè laminato oro 80006 cat.7.

Molly ottoman 80x80 cm in pony coffee gold laminate 80006 cat.7.

Hocker Molly 80x80 cm in Fell Kaffee mit Gold 80006 Kat.7.

Pouf Molly 80x80 cm en poney café stratifié or 80006 cat.7.





Pouf Molly 80x80 cm in cavallino bianco laminato oro 80045 cat.7.

Molly ottoman 80x80 cm in pony white laminate gold 80045 cat.7.

Hocker Molly 80x80 cm in weißem Edel Fell mit gold 80045 Kat.7.

Pouf Molly 80x80 cm en poney blanc 80045 stratifié or cat.7.

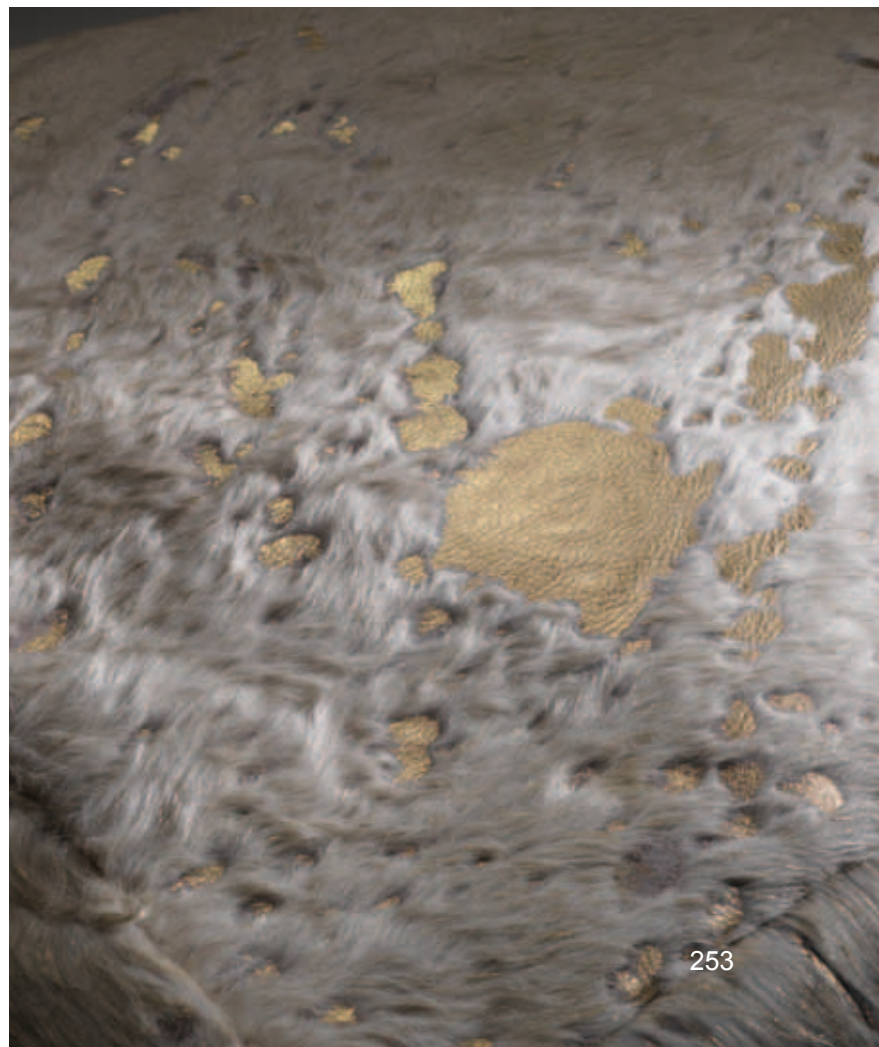



Ego

design Studio Tecnico Gyform

Pouf Ego in velluto ostrica
363/02 cat.C.

Footstool Ego in velluto ostrica
363/02 cat.C.

Hoecker Ego in velluto ostrica
363/02 Kat.C.

Pouf Ego in velluto ostrica
363/02 cat.C.

Cubo

design Studio Tecnico Gyform

Pouf Cubo 42x42 cm in pelle mucca tricolore 70301 cat.6 con piedi faggio tinta wengè.

Footstool Cubo 42x42 cm leather cowskin tricolor 70301 cat.6 with foot beech wenge.

Hoecker Cubo 42x42 cm Leder Kuhfell dreifarbig 70301 Kat.6 mit Fuß Buche wenge.

Pouf Cubo 42x42 cm en cuir vache tricolore 70301 cat.6 à pied hêtre wengé.



06.

DATI TECNICI

TECHNICAL DATA

Boss

Divano
Sofa

Elemento laterale dx o sx
Right or left unit

Elemento centrale
Central unit

Pouf
Pouf

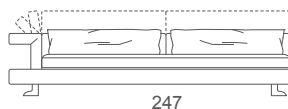
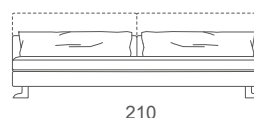
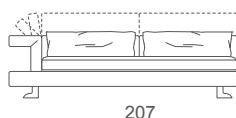
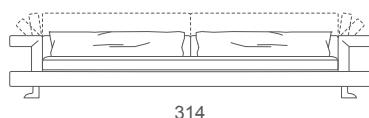
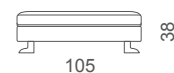
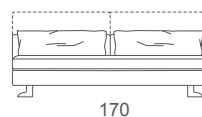
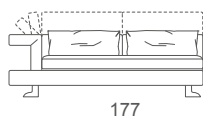
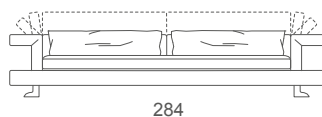
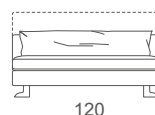
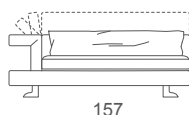
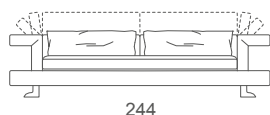
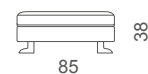
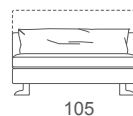
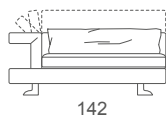
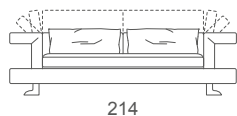
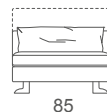
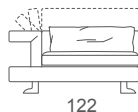
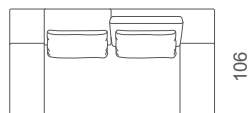
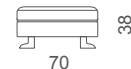
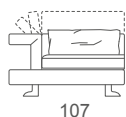
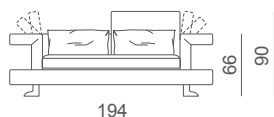

Design: Alessia Gasperi

Struttura in legno con cinghie elastiche rivestita con poliuretano espanso indeformabile e tessuto protettivo accoppiato. Cuscini seduta e schienale in poliuretano espanso indeformabile e Dacron; cuscini ed appoggiareni in piuma. Piedini in metallo con finitura bronzata. Rivestimento in tessuto sfoderabile. In pelle è fisso. Schienale e bracciolo reclinabile in 12 posizioni.

Hardwood structure covered in polyurethane with a protective fabric lining. Interwoven elastic webbing. Seat and back cushion in polyurethane and Dacron. Kidney rest pillows in feather. Legs with bronze finishing. Backrest and arm adjustable in 12 positions.

Das Gestell ist aus Massivholz, der Polsteraufbau aus hochwertigen Schaumstoffen. Korpusbezug aus weißen Nylonvelour. Sitzaufbau aus Metall mit geprüften Trambolin Gummigurten. Sitz und Rueckenkissen aus hochelastischen Kaltschäumen und Dacronwatte. Nierenkissen aus Kaltschaum und Daunen. Füße bronziert. Rückenkissen und Armteile sind in 12 verschiedenen Positionen verstellbar.

Structure en bois massif avec sangle elastique XL tissées entrecroisées revêtues de polyuréthane expansé et de tissu de protection assorti. Cuscins d'assises et dossiers en polyuréthane expansé et dacron. Pieds metal finition bronze. Dossiers et accoudoirs relelables en 12 positions.

Boss

Angolo terminale
Corner terminal

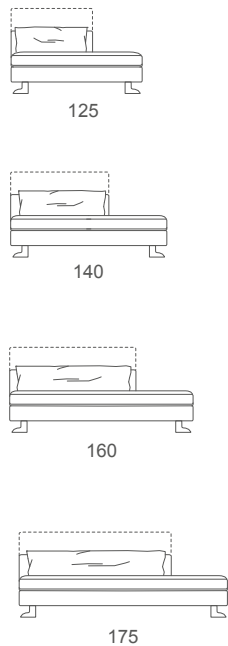

Chaise longue
Chaise longue

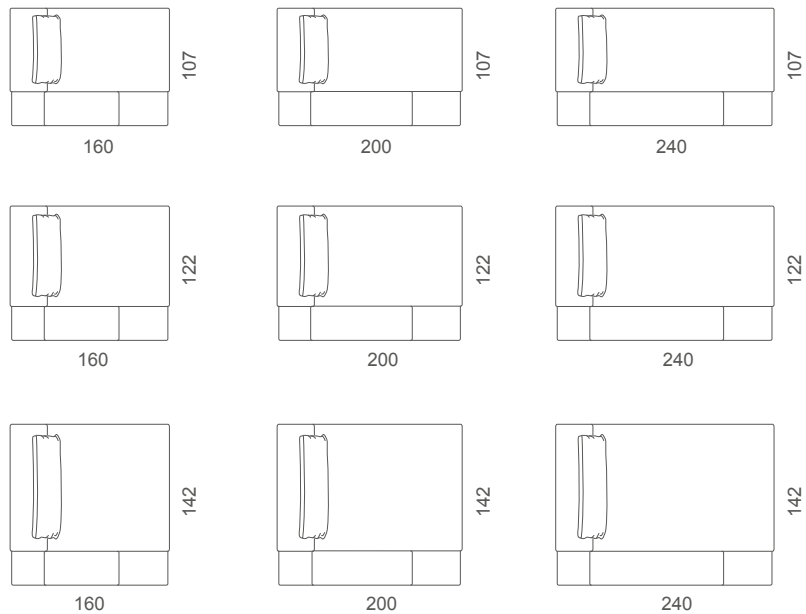

Librerie
Bookcases

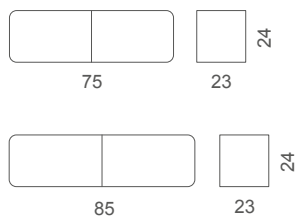

Vassoi
Trays

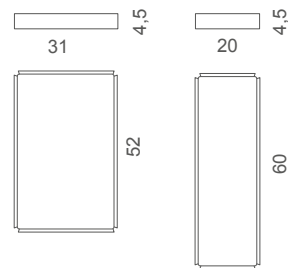

Cuscini
Pillows



Smart

Divano
Sofa

Elemento laterale dx o sx
Right or left unit

Elemento centrale
Central unit

Pouf
Pouf

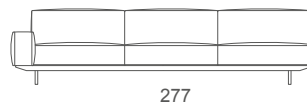
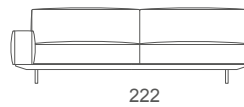
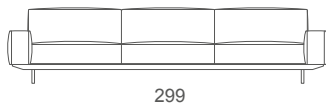
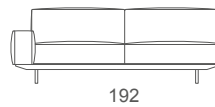
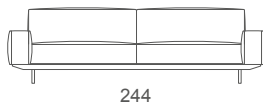
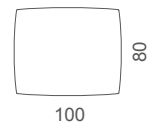
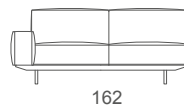
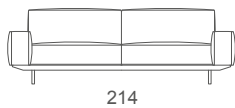
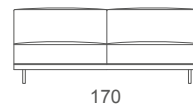
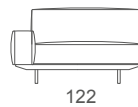
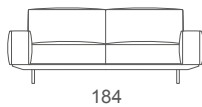
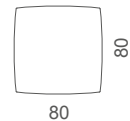
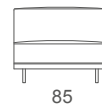
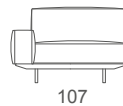
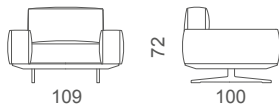
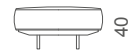
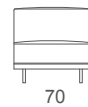
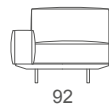
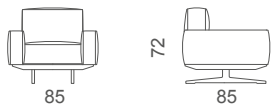

Design: Alessia Gasperi

Struttura in legno con cinghie elastiche rivestita con poliuretano espanso indeformabile e trapuntino in piuma. Cuscini seduta in poliuretano espanso indeformabile con trapuntino in piuma. Cuscini in piuma; piedini bronzati o cromati; rivestimento in tessuto sfoderabile. In pelle è fisso.

Hardwood structure covered in polyurethane with a protective fabric lining. Interwoven elastic webbing. Seat, back and arm cushions in polyurethane and Feather. Legs in metal bronzed or chrome. Completely removable fabric upholstery. Leather covering is fixed (non-removable).

Gestell aus Massivholz. Sitz unterfederung mit geprüften Trambolin Gummigurten dicht bespannt. Arm, Sitz und Rückenissen aus hochelastischen Kaltschäumen und Daunenfüllung. Füße brüniert oder in Chrom. Stoff-Bezüge vollständig abziehbar.

Structure en bois massif avec sangle XL élastiques tressées entrecroisées revêtues de polyuréthane expansé et de tissu de protection assorti. Cuscin d'assise, accoudoir et dossier en polyuréthane expansé et plumes. Revêtement en tissu déhoussable. En cuir le revêtement est fixe. Pieds bronze ou chromé.

Smart

Angolo terminale
Corner terminal

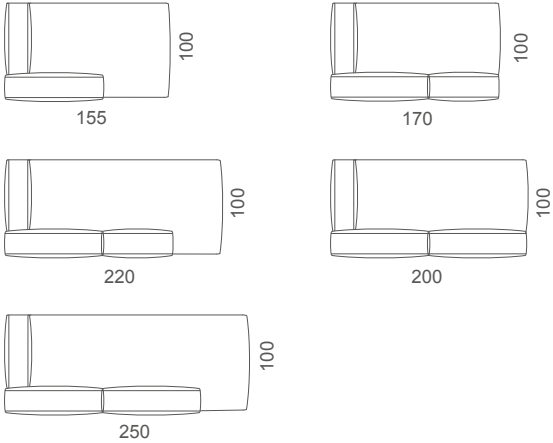

Chaise longue
Chaise longue

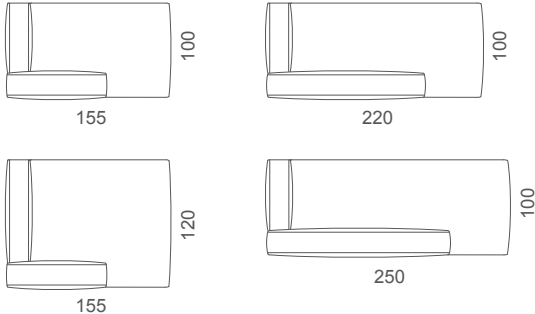

Cuscini
Pillows

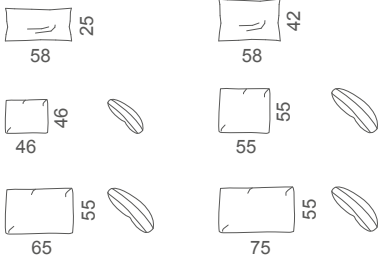

Focus

Divano
Sofa

Elemento laterale dx o sx
Right or left unit

Elemento centrale
Central unit

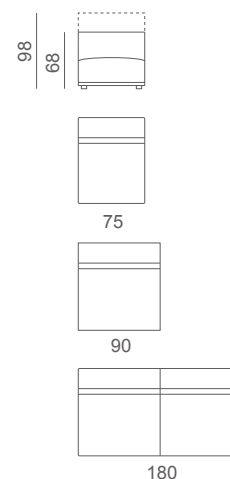
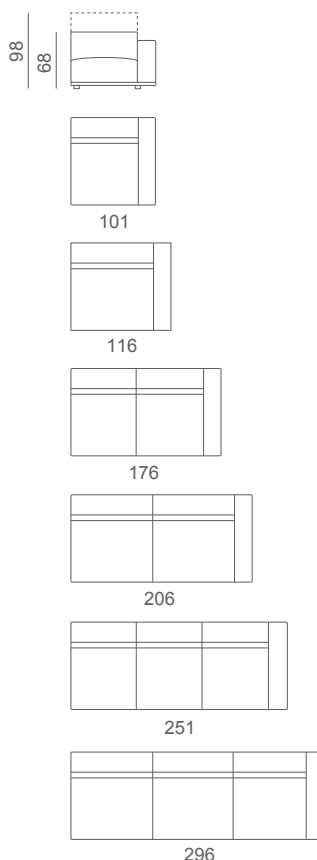
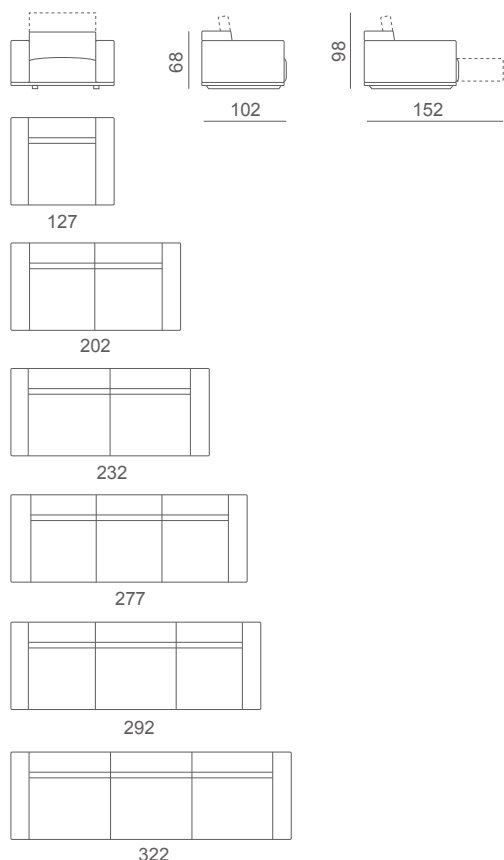

Design: studio tecnico Gyform

Struttura in legno con cinghie elastiche rivestita con poliuretano espanso indeformabile e tessuto protettivo accoppiato; telaio interno meccanismo in metallo verniciato. Cuscini seduta in poliuretano espanso indeformabile e piuma; cuscini schienale e braccioli in poliuretano espanso con trapuntino in piuma. Seduta estraibile in 4 diverse posizioni con prolunga a scomparsa, con estensione massima di 50 cm (profondità seduta da 55 cm, 65 cm, 75 cm e 105 cm). Schienale reclinabile in 12 posizioni.

Hard wood structure with varnished metal parts covered in polyurethane with a protective fabric lining. Interwoven elastic webbing. Arm, back and seat cushion polyurethane and feathers. Seat with relax system that allows to reach 4 different depths with 50 cm more than standard (seat depth from 55 cm, 65 cm, 75 cm and 105 cm). Backrest adjustable in 12 positions with the new "No Fold Marks" technology .

Das Gestell ist aus Massivholz, der Polsteraufbau aus hochwertigen Schaumstoffen. Korpusbezug aus weißen Nylonvelour. Sitzaufbau aus Metall mit geprüften Trambolin Gummigurten. Armteil, Ruecken und Sitzkissen aus hochelastischen Kaltschaum und Daunen. Der Sitzauszug hat 4 verschiedenen Positionen mit einer Sitztiefenverstellung bis Maximal 50 cm. Daraus ergibt sich eine Sitztiefe von 55 cm, 65 cm, 75 cm oder 105 cm. Die Rückenissen sind in 12 verschiedenen Positionen zu verstellen mit der neuen Technologie "Faltenlos".

Structure en bois massif et metal avec sangle elastique tissées entrecroisées revêtues de polyuréthane expansé indéformable et de tissu de protection assorti. Accoudoir, coussin d'assise et de dossier en polyuréthane expansé et plume. Assise relax (4 positions différentes extension maximum 50 cm (profondeur assise 55 cm, 65 cm, 75 cm et 105 cm). Dossier réglable en 12 positions avec une nouvelle technologie "sans pli".

Focus

Chaise longue dx o sx
Chaise longue with right or left arm

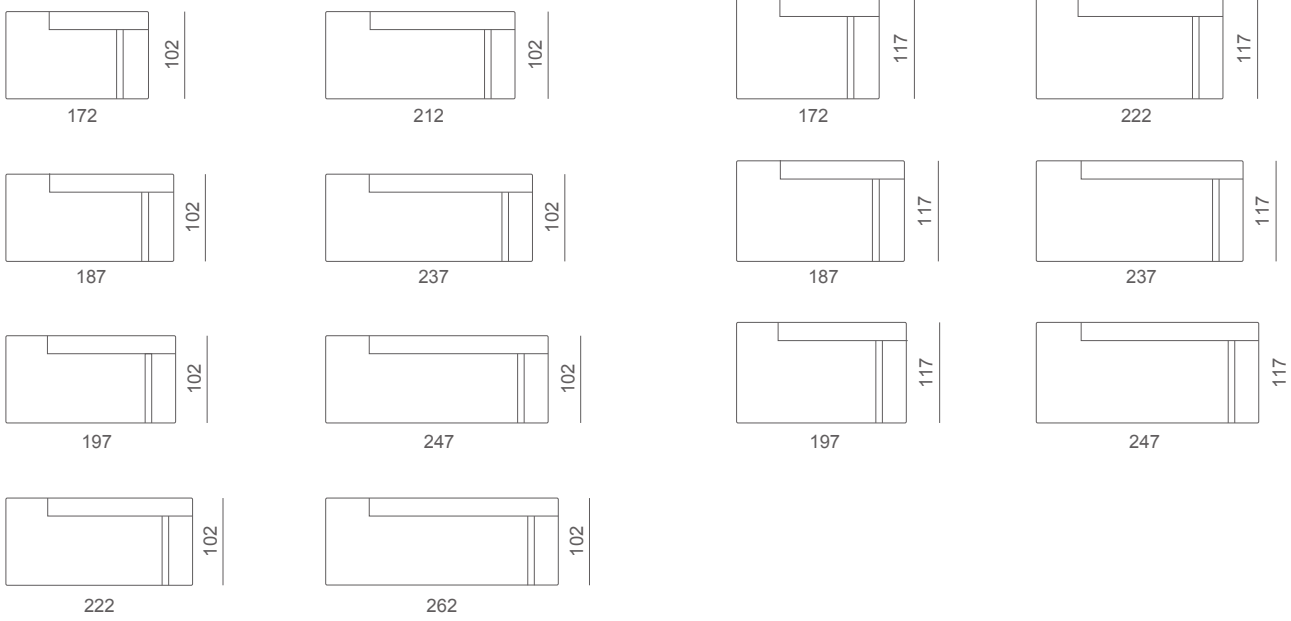

Angolo dx o sx
Right or left corner

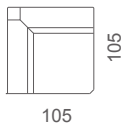

Pouf
Pouf

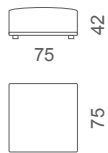

Cuscini
Pillows



Ghost

Divano
Sofa

Elemento laterale dx o sx
Right or left unit

Elemento centrale
Central unit

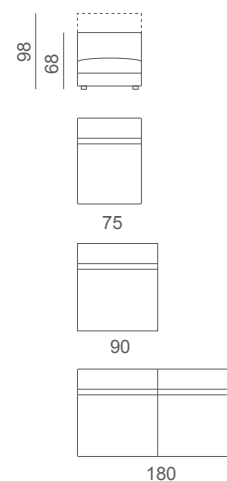
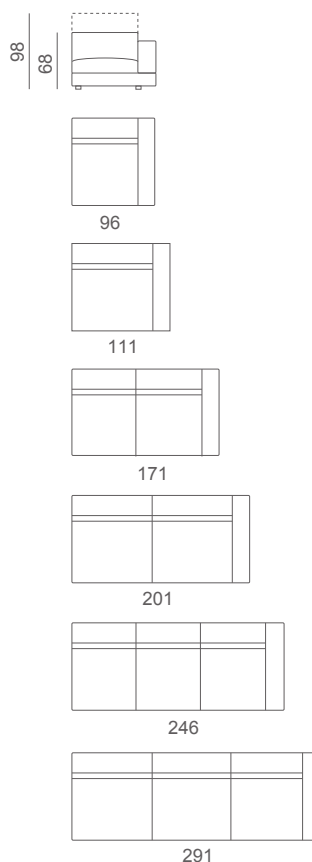
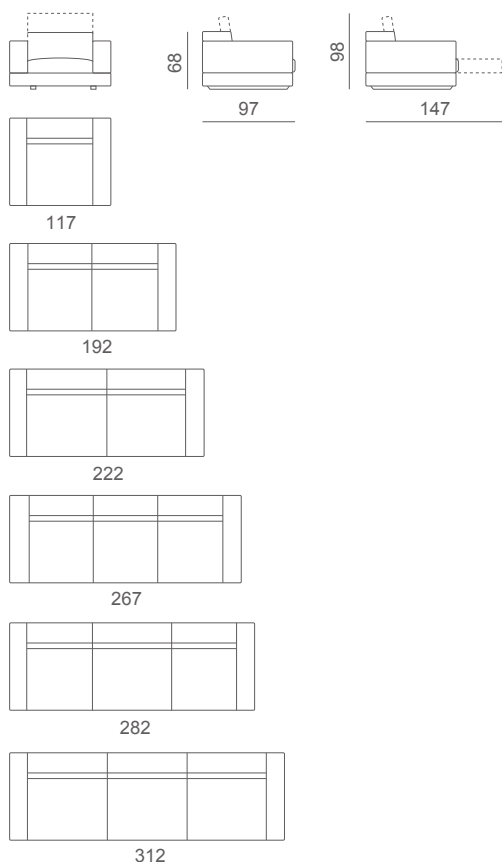

Design: Giulio Manzoni

Struttura in legno con cinghie elastiche rivestita con poliuretano espanso indeformabile e tessuto protettivo accoppiato; telaio interno meccanismo in metallo verniciato. Cuscini seduta in poliuretano espanso indeformabile e Dacron; cuscini schienale in poliuretano espanso con trapuntino in piuma. Struttura schienale e braccioli smontabili con meccanismo a baionetta; Rivestimento in tessuto sfoderabile. In pelle è fisso. Divani e terminali nella versione con bracciolo lungo (a filo fusto) oppure bracciolo corto (da specificare nell'ordine). Seduta estraibile in 4 diverse posizioni con prolunga a scomparsa con estensione massima di 50 cm (profondità seduta da 55 cm, 65 cm, 75 cm e 105 cm). Schienale reclinabile in 12 posizioni e con nuova tecnologia "senza piega".

Hard wood structure with varnished metal parts covered in polyurethane with a protective fabric lining. Interwoven elastic webbing. Seat cushion in polyurethane and Dacron. Back cushion polyurethane and feathers. Back frame and armrest detachable through a bayonet mechanism. Completely removable fabric upholstery. Leather covering is fixed. Version with long or short arm for terminals and sofas (to specify in the order). Seat with relax system that allows to reach 4 different depths with 50 cm more than standard (seat depth from 55 cm, 65 cm, 75 cm and 105 cm). Backrest adjustable in 12 positions with the new "No Fold Marks" technology.

Das Gestell ist aus Massivholz, der Polsteraufbau aus hochwertigen Schaumstoffen. Der Korpusbezug aus weißen Nylonvelour. Sitzaufbau des Federgrundes aus Metall mit geprägten Trambolin Gummigurten dicht bespannt. Sitzkissen aus hochelastischen Kaltschaum und Dacron. Rückenkissen aus Kaltschaum und Daunen. Armlehnen und Rückenlehne sind abnehmbar bei dem Mechanismus mit Bajonettverschluss. Die Stoffbezüge sind vollständig abziehbar und waschbar. Sofa und Endelement mit Ausführung langen Armteil oder mit kurzem Armteil (zum notieren in die Bestellung). Der Sitzauszug hat 4 verschiedenen Positionen mit einer Sitztiefeverstellung bis Maximal 50 cm. Daraus ergibt sich eine Sitztiefe von 55 cm, 65 cm, 75 cm oder 105 cm. Die Rückenkissen sind in 12 verschiedenen Positionen zu verstellen mit der neuen Technologie "Faltenlos".

Structure en bois massif avec sangles élastiques entrecroisées revêtues de polyuréthane expansé indéformable et tissu de protection assorti; châssis intérieur mécanisme en métal verni. Coussins d'assise en polyuréthane expansé et Dacron; coussins dossier en polyuréthane expansé indéformable et plume. Structure dossier et accoudoir démontables avec mécanisme à baïonnette. Revêtement en tissu déhoussable, en cuir fixe. Terminal et canapés avec bras long ou bras court. Assise relax (4 positions différentes extension maximum 50 cm (profondeur assise 55 cm, 65 cm, 75 cm et 105 cm). Dossier réglable en 12 positions avec une nouvelle technologie "sans pli".

Ghost

Chaise longue dx o sx
Chaise longue with right or left arm

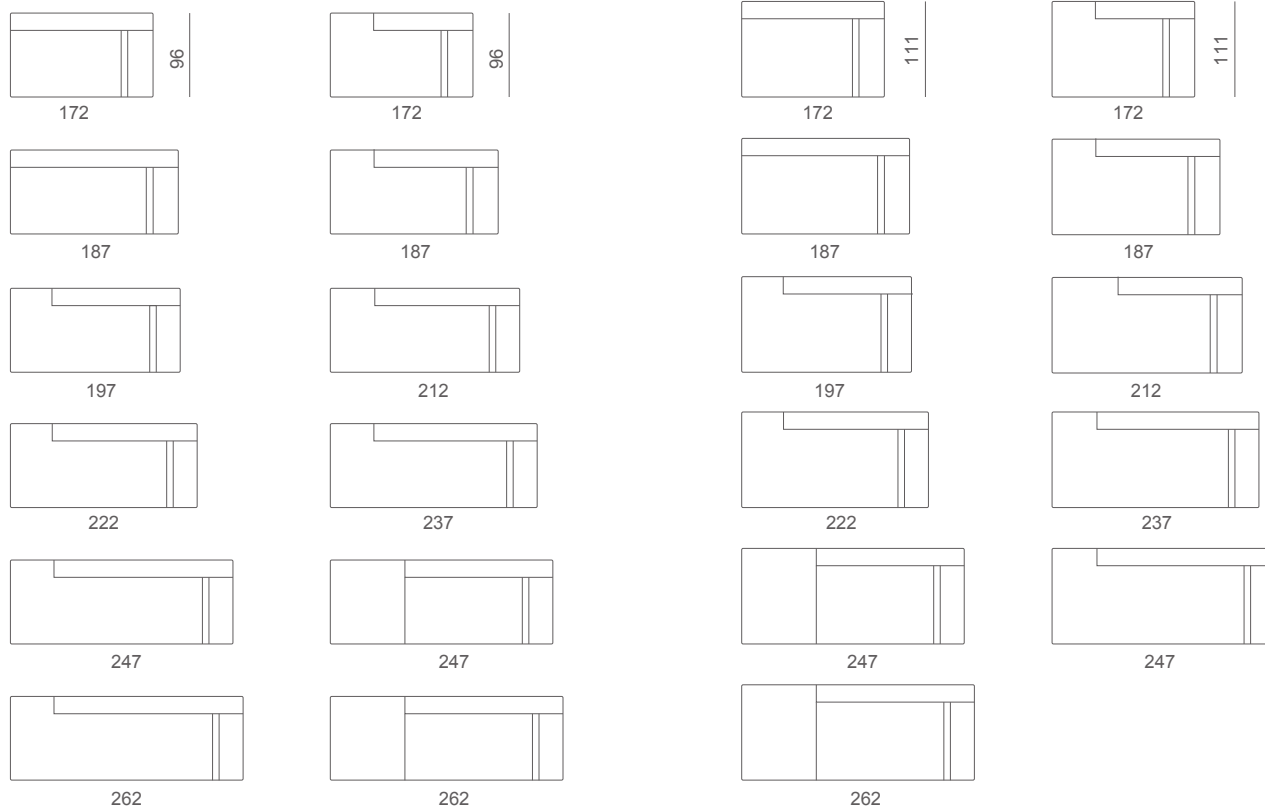

Angolo dx o sx
Right or left corner

Pouf
Pouf

Cuscini
Pillows

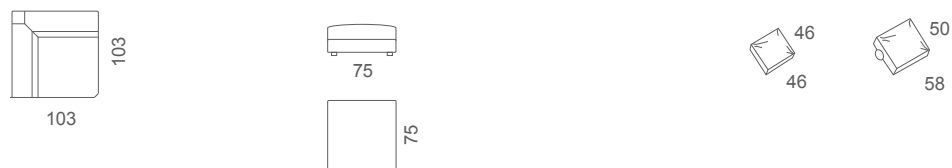

Planet

Divano
Sofa

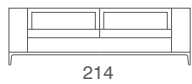
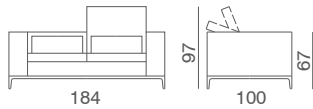

Elemento laterale dx o sx
Right or left unit

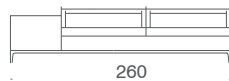
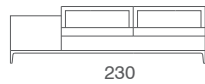
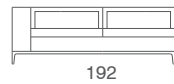
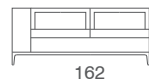
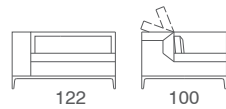

Elemento centrale
Central unit

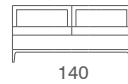
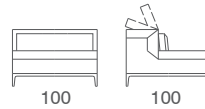

Chaise longue dx o sx
Chaise longue with right or left short arm

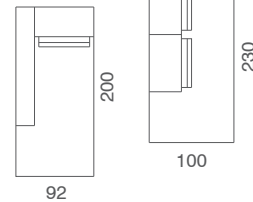
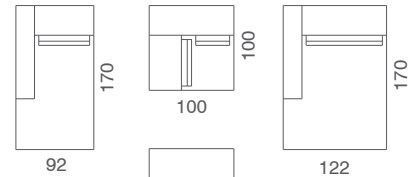
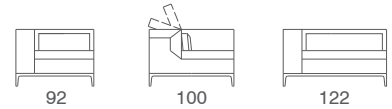

Pouf
Pouf

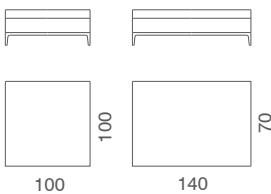

Cuscini
Pillows



Design: studio tecnico Gyform

Struttura in legno con cinghie elastiche rivestita con poliuretano espanso indeformabile e tessuto protettivo accoppiato. Cuscini seduta in poliuretano espanso indeformabile con trapuntino in piuma; cuscini schienale in espanso indeformabile e piuma. Su richiesta cuciture punto cavallo su braccioli e cuscini schienale. Cuscinetti appoggiareni in piuma. Base cromata o finitura bronzata. Cuscini schienale reclinabili in 2 posizioni (alta o bassa). Rivestimento in tessuto sfoderabile. In pelle è fisso.

Hard wood structure. Interwoven elastic webbing. Seat cushions in polyurethane with covering in goose down; back cushions in polyurethane and goose down. Kidney rest cushion in down. Base chrome or bronzed finishing. Backrest are adjustable in two positions (high or low). On request stitching "punto cavallo". Completely removable fabric upholstery.

Gestell aus Massivholz. Sitzaufbau mit geprüften Trambolin-Gummigurten dicht bespannt. Sitzkissen aus Schaum mit einer Abdeckung aus Daunen; Rückenkissen aus hochelastischen Kaltschaum und Daunen. Basis chrome oder bronziert. Rückenkissen mittels Mechanismus verstellbar (2 Positionen). Nahtausführung: "Punto Cavallo" oder standard. Stoff-Bezüge vollständig abziehbar.

Structure en bois avec sangles élastiques entrecroisées revêtues de polyuréthane expansé indéformable et de tissu de protection assorti. Coussin d'assise et dossier en polyuréthane expansé et plume. Revêtement en tissu dehoussable. Dossier relevable. Couture "Punto Cavallo" ou standard. Base tubulaire chrome ou bronz.

Eliot

Divano
Sofa

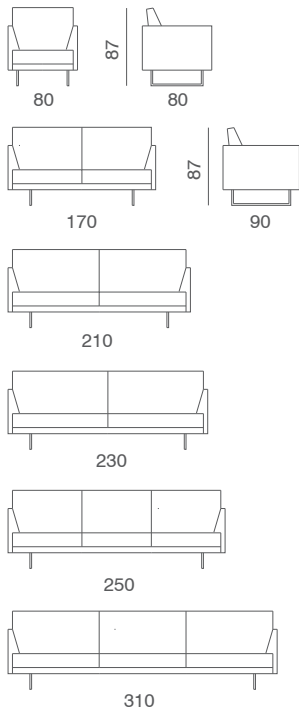

Elemento laterale dx o sx
Right or left unit

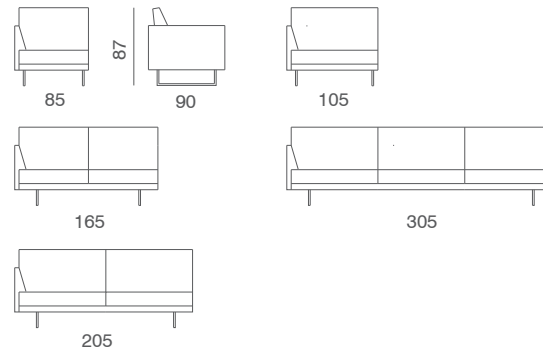

Elemento centrale
Central unit

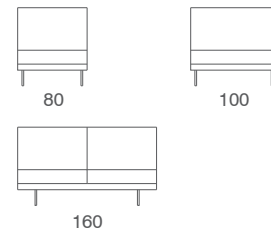

Chaise longue dx o sx
Chaise longue with right or left short arm

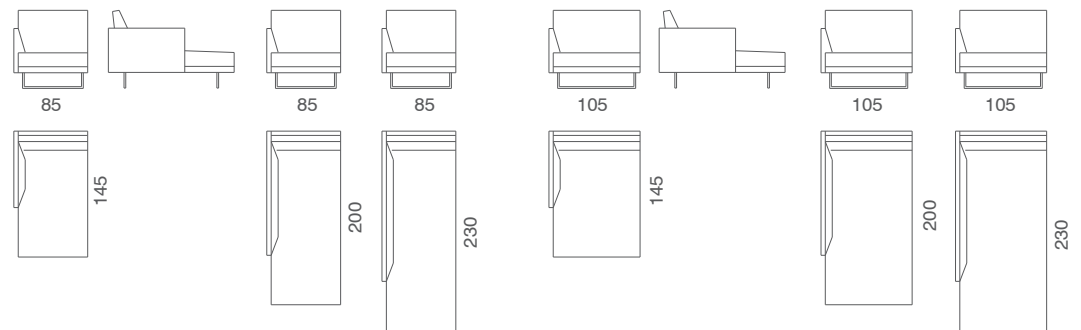

Pouf
Pouf

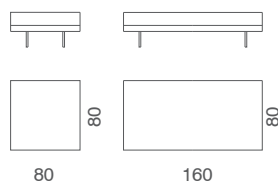

Cuscini
Pillows



Design: studio tecnico Gyform

Struttura in legno con cinghie elastiche rivestita con poliuretano espanso indeformabile e tessuto protettivo accoppiato. Cuscini seduta in poliuretano espanso indeformabile con trapuntino in piuma; cuscini schienale in piuma. Rivestimento in tessuto sfoderabile. Il fianco del bracciolo può essere trapuntato o liscio. In pelle è fisso. Il piedino è in acciaio lucido.

Hard wood structure covered in polyurethane with a protective fabric lining. Interwoven elastic webbing. Seat cushion in polyurethane and feather. Back cushion in feather. Completely removable fabric upholstery. Leather covering is fixed. The leg is polished steel. By the order specify always if the arm side need to be quilted or not.

Die Struktur besteht aus Holz, das Untergestell besteht aus einem Metallrahmen und wird mit geprüften Trambolin Gummigurten dicht bespannt, der Polsteraufbau wird mit hochwertigen Schaumstoffen komplettierten geprüften Trambolin Gummigurten dicht bespannt. Die Sitzkissen sind aus hochelastischen Kaltschaum und mit Daunen gefüllt. Alle Rückenkissen sind komplett mit Daunen gefüllt. Die Stoffbezüge sind vollständig abziehbar und waschbar. Die Fussspannen des Sofas Zelig sind aus poliertem Edelstahl. Bitte bei der Bestellung angeben, ob die Außenseite der Armlehne gesteppt oder nicht gesteppt sein soll.

Structure en bois massif avec sangles élastiques XL tissées entrecroisées revêtues de polyuréthane avec tissu de protection assorti. Coussins d'assise en polyuréthane expansé haute resiliance recouvert d'une couette en plume; coussins de dossier en plume. Revêtement en tissu déhoussable, et cuir fixe. Pieds en acier chromé. À la commande s'il vous plaît préciser si l'extérieur de l'accoudoir doit être matelassé ou non.

Zelig

Divano
Sofa

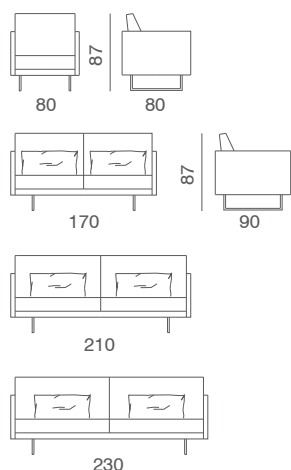

Elemento laterale dx o sx
Right or left unit

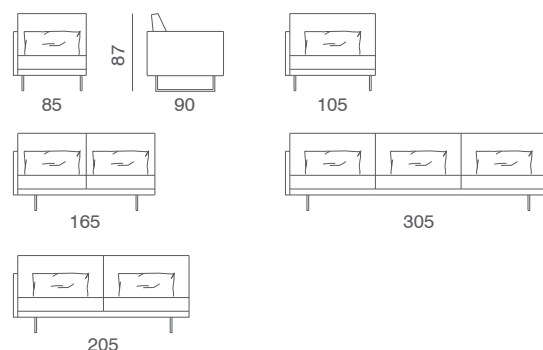

Elemento centrale
Central unit

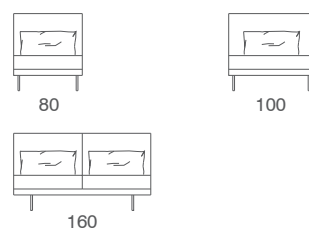

Chaise longue dx o sx
Chaise longue with right or left short arm

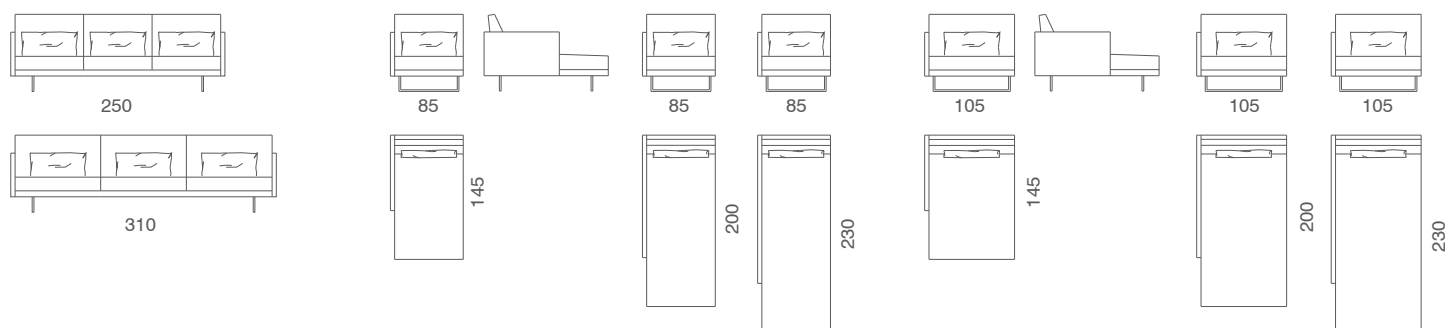

Pouf
Pouf

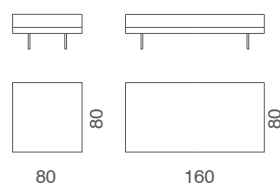

Cuscini
Pillows



Design: studio tecnico Gyform

Struttura in legno con cinghie elastiche rivestita con poliuretano espanso indeformabile e tessuto protettivo accoppiato. Cuscini seduta in poliuretano espanso indeformabile con trapuntino in piuma; cuscini schienale in piuma. Rivestimento in tessuto sfoderabile. In pelle è fisso. Il piedino è in acciaio lucido. Il cuscinetto intrecciato è disponibile solo in pelle (non in tessuto); i cuscinetti appoggia reni sono già inclusi nei vari elementi.

Hard wood structure covered in polyurethane with a protective fabric lining. Interwoven elastic webbing. Seat cushion in polyurethane and feather. Back cushion in feather. Completely removable fabric upholstery. Leather covering is fixed. The leg is polished steel. The woven pillow is only available in braided leather (not in fabric); kidney rest pillows are already included in the various elements.

Gestell aus Massivholz, der Polsteraufbau aus hochwertigen Schaumstoffen. Der Korpusbezug aus weißen Nylonvelour. Unser Sitzaufbau des Federgrundes ist aus Metall und wird mit geprüften Trambolin Gummigurten dicht bespannt. Die Sitzkissen sind aus hochelastischem Kaltschaum und mit Daunen gefüllt. Alle Rückenkissen sind komplett mit Daunen gefüllt. Die Stoffbezüge sind vollständig abziehbar und waschbar. Zelig hat seine Füße in Edelstahl poliert. Die Kissen "geflochten" sind nur in Leder verfügbar (nicht in Stoff).

Structure en bois massif recouverte en polyuréthane avec tissu de protection assorti. Coussins d'assise en polyuréthane expansé et plume; coussins de dossier en plume matelassé. Revêtement en tissu déhoussable, et cuir fixe. Pieds en acier poli. Le coussin tressé 50x50 disponible en cuir seulement; les coussins cale-reins sont déjà inclus.

Eagle

Divano
Sofa

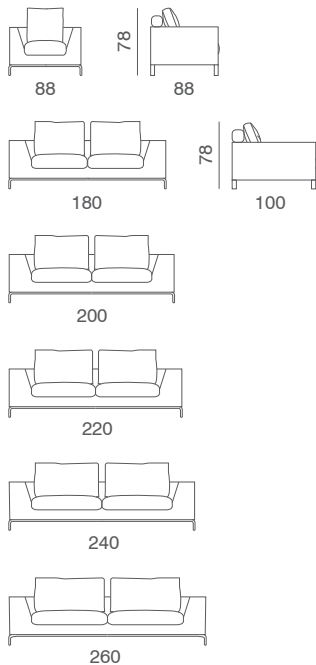

Elemento laterale dx o sx
Right or left unit

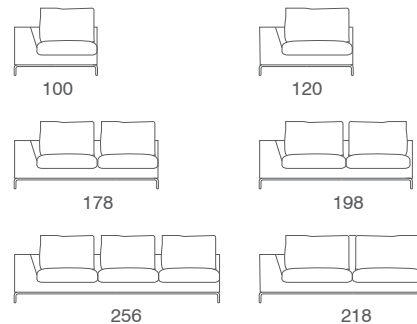

Elemento centrale
Central unit



Dormeuse
Dormeuse

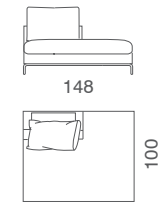

Chaise longue dx o sx
Chaise longue with right or left short arm

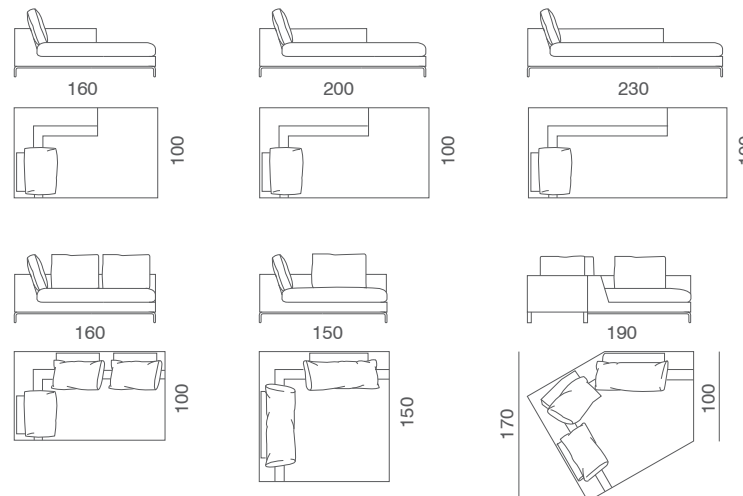

Cuscini
Pillows

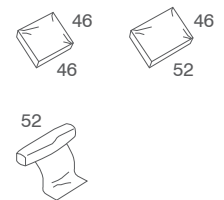

Pouf
Pouf

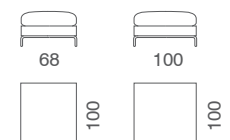

Design: studio tecnico Gyform

Struttura in legno con cinghie elastiche rivestita con poliuretano espanso indeformabile e tessuto protettivo accoppiato. Cuscini seduta in poliuretano espanso indeformabile con trapuntino in piuma; cuscini schienale in piuma. Rivestimento in tessuto sfoderabile. In pelle è fisso. Il piedino è in alluminio satinato. I rulli appoggiatesta sono indipendenti dal cuscino schienale e sono fissati alla struttura con il velcro.

Hard wood structure covered in polyurethane with a protective fabric lining. Interwoven elastic webbing. Seat cushion in polyurethane and feather. Back cushion in feather. Completely removable fabric upholstery. Leather covering is fixed. Feet in Aluminium Mat. The back roll headrest are independent from the back cushions and are fixed to the frame with Velcro.

Das Gestell ist aus Massivholz, der Polsteraufbau aus hochwertigen Schaumstoffen. Der Korpusbezug aus weißen Nylonvelour. Sitzaufbau des Federgrundes aus Metall mit geprüften Trambolin Gummigurten dicht bespannt. Sitzkissen aus hochelastischen Kaltschaum und Daunen. Die Rückenkissen sind mit Daunen gefüllt. Die Stoffbezüge sind vollständig abziehbar und waschbar. Füße Aluminium / Matt. Die hinteren Roll-Kopfstützen sind unabhängig vom Rückenkissen und werden mit Klettband am Rahmenfixiert.

Structure en bois massif avec sangles élastiques entrecroisées extra-large XL tissées avec du fil de nylon revêtues de polyuréthane expansé et de tissu de protection assorti. Coussins d'assise en polyuréthane expansé et plume matelassé; coussins de dossier en plume. Revêtement en tissu déhoussable; en cuir fixe. Pieds en aluminium mat. Les appui-têtes rouleaux arrière sont indépendants des coussins de dossier et sont fixés à la structure avec Velcro.

Plan

Divano
Sofa

Elemento laterale dx o sx
Right or left unit

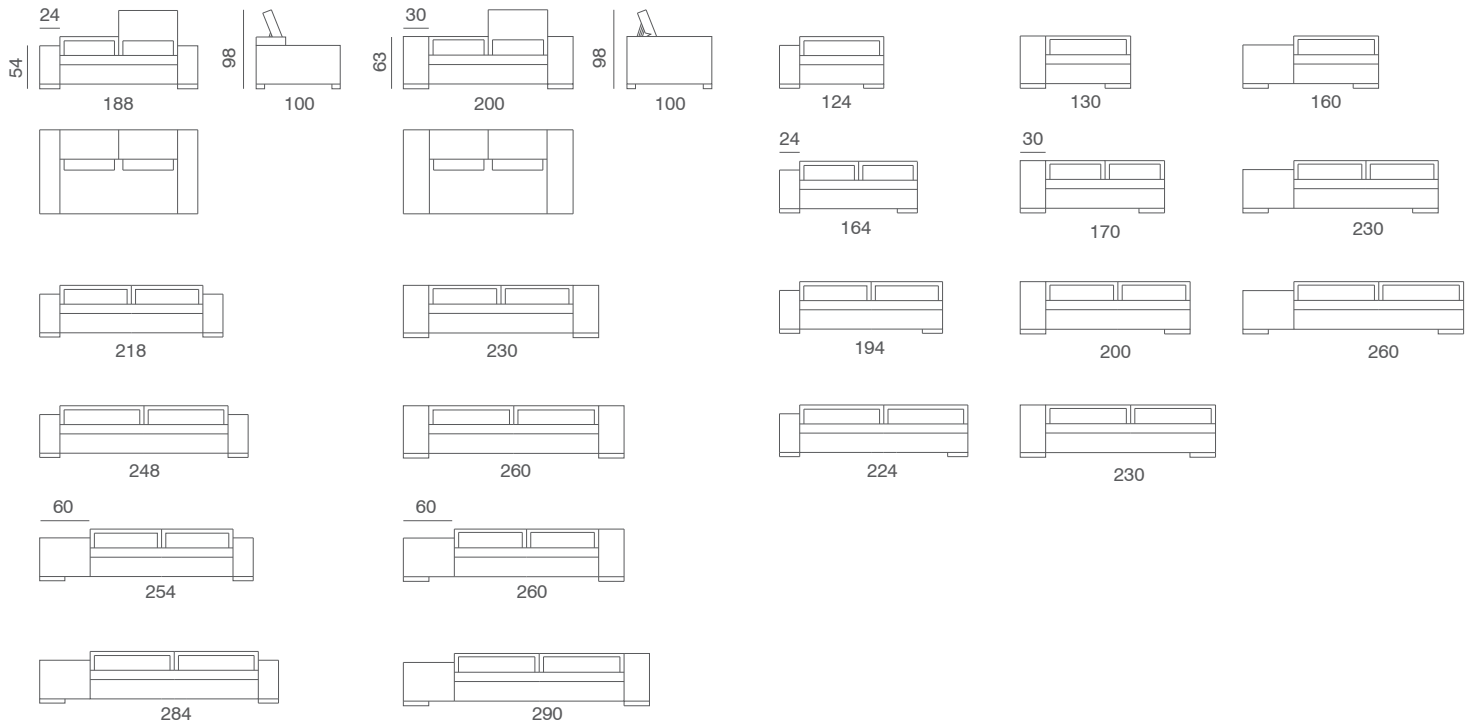

Design: studio tecnico Gyform

Struttura in legno con cinghie elastiche rivestita con poliuretano espanso indeformabile e tessuto protettivo accoppiato. Cuscini seduta in poliuretano espanso indeformabile con trapuntino in Dacron (su richiesta in piuma); cuscini schienale in espanso indeformabile e Dacron. Appoggiareni in piuma con supporto in poliuretano espanso. Versione con bracciolo alto largo 30 cm con piedi a lama in alluminio oppure con piedino 30x10x4 cm in acciaio o base tubolare; versione con bracciolo da 24 cm con piedino 24x11x3 cm in acciaio oppure base tubolare. Rivestimento in tessuto sfoderabile. In pelle è fisso.

Hard wood structure covered in polyurethane with a protective fabric lining. Interwoven elastic webbing. Seat cushions in polyurethane with covering in Dacron (or in goose down on request); back cushions in polyurethane and Dacron. Kidney rest cushion in foam and down. Version with high/large arm (30 cm) with aluminium edge legs or with block steel leg 30x10x4 cm or tubular base. In the version with low arm 24 cm wide with steel legs 24x10x4 cm or tubular base. Backrest are adjustable in different positions. Completely removable fabric upholstery. Leather covering is fixed.

Gestell aus Massivholz, Polsteraufbau mit hochwertigen Schaumstoffen. Korpusbezug aus weißen Nylonvelour. Sitzaufbau des Federgrundes mit geprüften Trambolin-Gummigurten dicht bespannt. Sitzkissen aus hochelastischen Kaltschaum mit einer Abdeckung aus Dacron (oder Daunen aus Wunsch); Rückenkissen aus hochelastischen Kaltschaum und Dacron. Armlehnkissen in Daunen und Schaum. Ausführung mit Armteil 30 cm Breite, mit Winkelfuß aus Aluminium oder mit Bodenplatte 30x10x4 cm aus Edelstahl oder durchgehende Gestell. Ausführung mit Armteil niedrig, Breite 24 cm mit Fuß aus Edelstahl poliert 24x11x4 cm oder durchgehende Gestell. Rückenkissen mittels Mechanismus verstellbar. Stoff Bezüge vollständig abziehbar.

Structure en bois massif et multiplis. Suspension avec sangles élastiques entrecroisées, revêtues de polyuréthane expansé indéformable et tissu de protection. Coussin d'assise en polyuréthane expansé indéformable et Dacron (ou plume); coussin de dossier en polyuréthane expansé indéformable et dacron. Coussin calle rein en plume. Option avec accoudoir haut large 30 cm avec pieds lama "L" aluminium ou avec pied 30x10x4 cm en acier ou socle en aluminium brillant; option avec accoudoir bas large 24 cm avec pieds 24x11x3 cm en acier ou socle en aluminium brillant. Coussin dossier réglable en différentes positions. Revêtement en tissu déhoussable. En cuir le revêtement est fixe.

Plan

Elemento centrale
Central unit

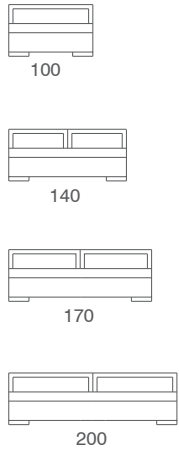

Chaise longue dx o sx
Chaise longue with right or left short arm

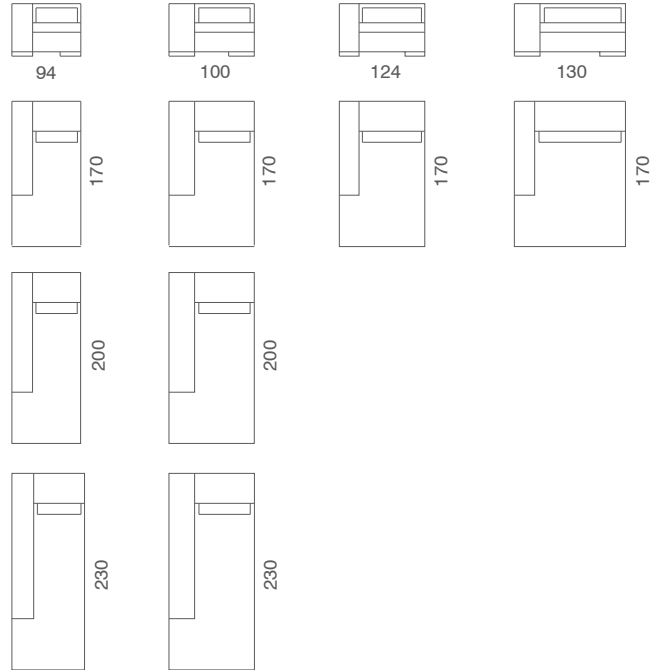

Angolo dx o sx
Right or left corner

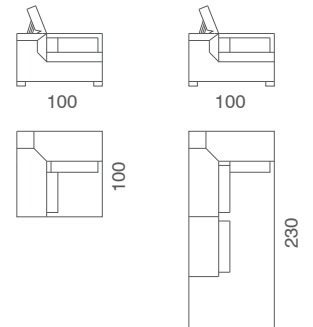

Pouf
Pouf

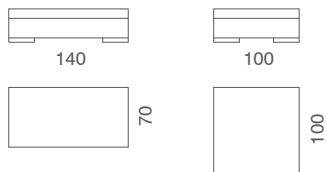

Accessori
Accessories

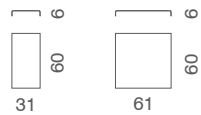

Cuscini
Pillows



Zoe

Divano
Sofa

Elemento laterale dx o sx
Right or left unit

Elemento centrale
Central unit

Chaise longue dx o sx
Chaise longue with right or left short arm

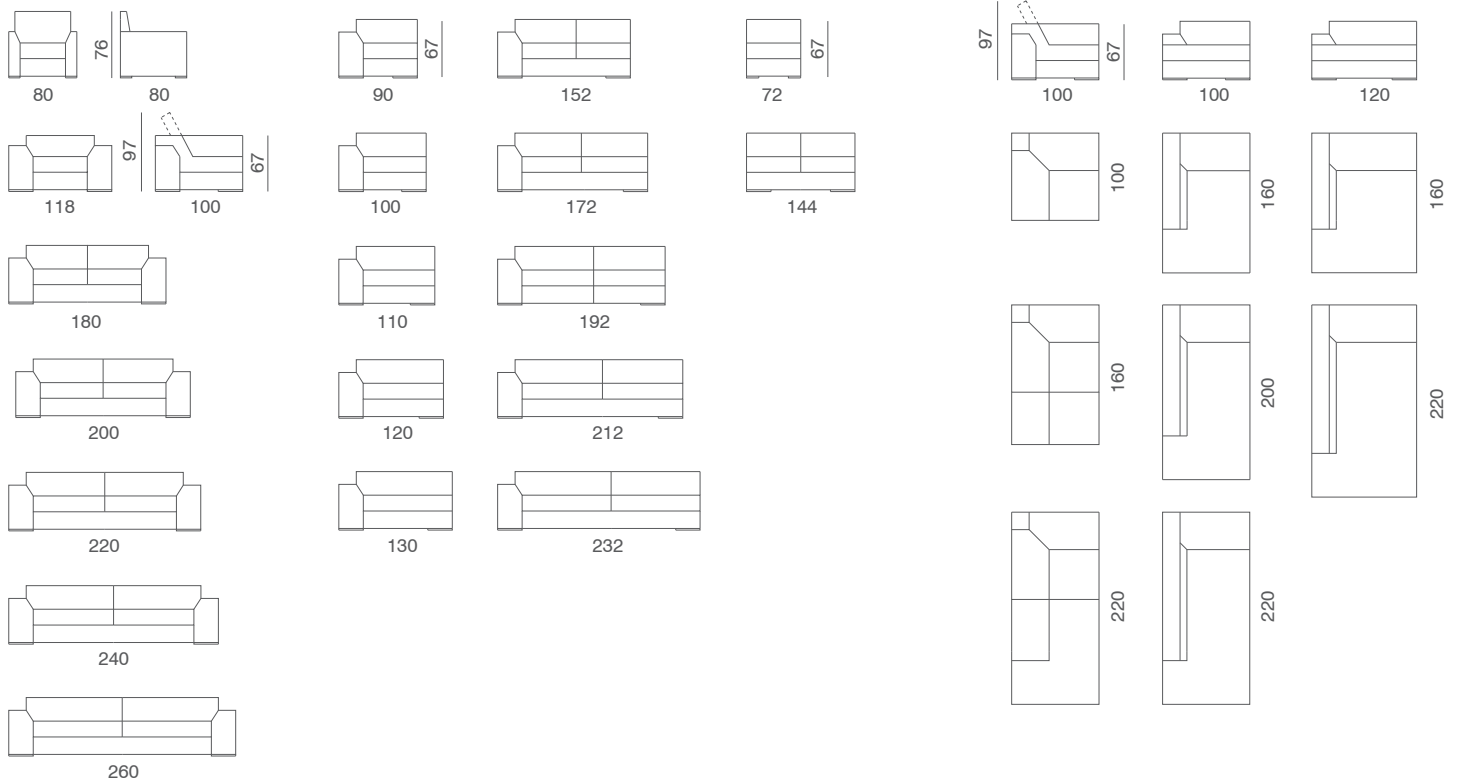

Pouf
Pouf

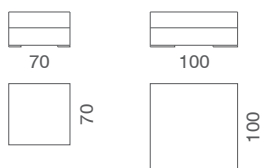

Design: studio tecnico Gyform

Struttura in legno con cinghie elastiche rivestita con poliuretano espanso indeformabile e tessuto protettivo accoppiato. Cuscini seduta in poliuretano espanso indeformabile con trapuntino in piuma; cuscini schienale in espanso indeformabile rivestito con trapuntino in piuma. Cuscini schienale reclinabili in 2 posizioni (alta o bassa); Piedini in metallo con finitura Nickel nero oppure in alluminio (satinato o lucido). Rivestimento in tessuto sfoderabile. In pelle è fisso.

Hard wood structure covered in polyurethane with a protective fabric lining. Interwoven elastic webbing. Seat cushions in polyurethane with covering in goose down; back cushions in polyurethane with layer in goose down. Legs in black Nickel-plated metal or in aluminium (mat or polished). Backrest are adjustable in different positions. Completely removable fabric upholstery. Leather covering is fixed.

Gestell aus Massivholz, Polsteraufbau mit hochwertigen Schaumstoffen. Korpusbezug aus weißen Nylonvelour. Sitzaufbau des Federgrundes mit geprüften Trambolin-Gummigurten dicht bespannt. Sitz und Rückenkissen aus hochelastischen Kaltschaum mit Abdeckung aus Daunen; Metallplatte Nickel schwarz oder Aluminium (poliert oder matt). Rückenkissen mittels Mechanismus verstellbar. Stoff Bezüge vollständigabziehbar.

Structure en bois massif avec sangles élastiques entrecroisées revêtues de polyuréthane expansé indéformable et tissu de protection assorti. Coussin d'assise et de dossier en polyuréthane expansé indéformable avec matelasse en plume; Pieds en métal noir Nickel ou aluminium. Coussin dossier inclinable en 2 différentes positions (haute ou basse). Revêtement en tissu déhoussable. En cuir le revêtement est fixe.

Longisland

Divano
Sofa

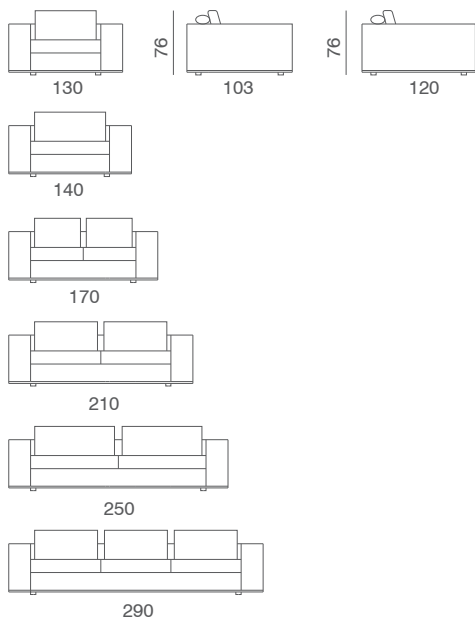

Elemento laterale dx o sx
Right or left unit

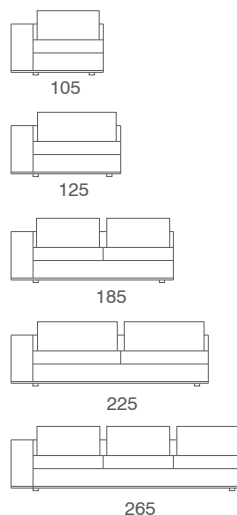

Elemento centrale
Central unit

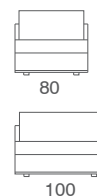

Pouf
Pouf

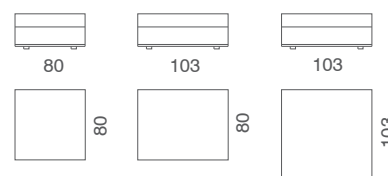

Chaise longue dx o sx
Chaise longue with right or left short arm

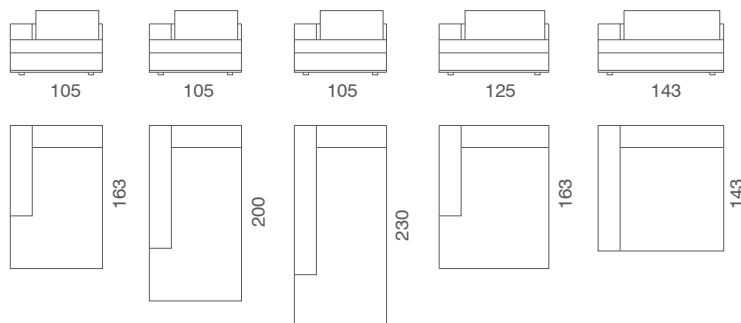

Cuscini
Pillows

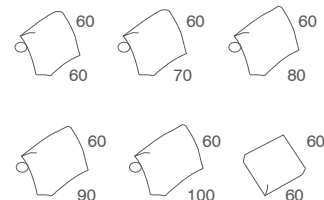

Design: studio tecnico Gyform

Struttura in legno con cinghie elastiche rivestita con poliuretano espanso indeformabile e tessuto protettivo accoppiato. Cuscini seduta in poliuretano espanso indeformabile e piuma; cuscini schienale e braccioli in piuma. Piedini in legno oppure base tubolare in alluminio lucido. Rivestimento in tessuto sfoderabile. In pelle è fisso.

Hard wood structure covered in polyurethane with a protective fabric lining. Interwoven elastic webbing. Seat cushions in goose down with resilient inner core; back cushions and arm in goose down. Legs in beech wood lacquered or tubular base in polished aluminium. Completely removable fabric upholstery. Leather covering is fixed.

Das Gestell ist aus Massivholz, der Polsteraufbau mit hochwertigen Schaumstoffen. Der Korpusbezug aus weißen Nylonvelour. Sitzaufbau des Federgrundes mit geprüften Trambolin Gummigurten dicht bespannt. Die Sitzkissen sind mit Federn gefüllt und mit einer unverformbaren Innenverstärkung versehen. Armlehnen und Rückenkissen in Daunen. Die Füße sind aus Holz gebeizt oder mit durchgehender Reling in Aluminium poliert erhältlich. Die Stoffbezüge sind vollständig abziehbar.

Structure en bois avec bandes élastiques, revêtue en polyuréthane indéformable et en tissu protecteur. Coussin d'assise en plume d'oie avec renfort en polyuréthane; coussins dossiers et d'accoudoir en plumes. Pieds en bois ou socle en aluminium brillant. Revêtement en tissu déhoussable. En cuir le revêtement est fixe.

Broadway

Divano
Sofa

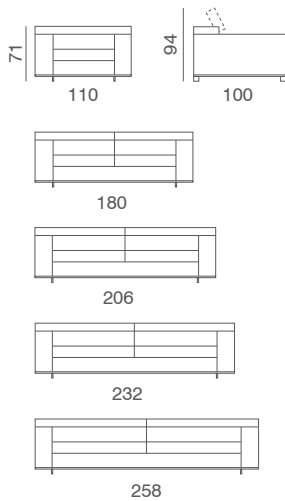

Elemento laterale dx o sx
Right or left unit

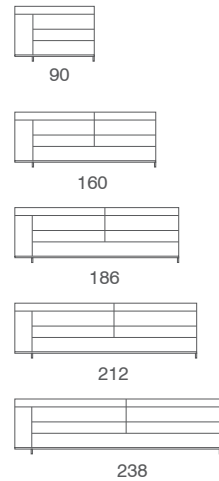

Elemento centrale
Central unit

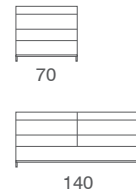

Pouf
Pouf

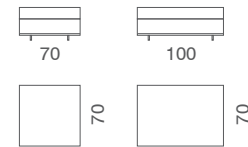

Cuscini
Pillows

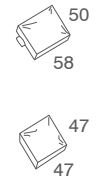

Chaise longue dx o sx
Chaise longue with right or left short arm

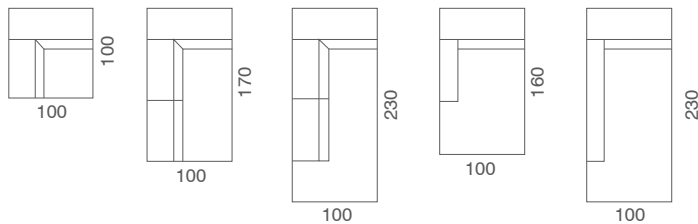

Dormeuse
Dormeuse



Design: studio tecnico Gyform

Struttura in legno con cinghie elastiche rivestita con poliuretano espanso indeformabile e tessuto protettivo accoppiato. Cuscini seduta e schienale in poliuretano espanso indeformabile con trapuntino in piuma; cuscini schienale reclinabili in 2 posizioni (alta o bassa); su richiesta versione con seduta relax. Piedini in metallo cromato. Rivestimento in tessuto o Alcantara sfoderabile. In pelle è fisso.

Hard wood structure covered in polyurethane with a protective fabric lining. Interwoven elastic webbing. Seat and back cushions in polyurethane with covering in goose down. Legs in chrome metal. Backrest are adjustable in two different positions. As option, version with seat relax (seat can be pulled out up to 22 cm). Completely removable fabric upholstery. Leather covering is fixed.

Gestell aus Massivholz, Polsteraufbau mit hochwertigen Schaumstoffen. Korpusbezug aus weißen Nylonvelour. Sitzaufbau des Federgrundes mit geprüften Trambolin-Gummigurten dicht bespannt. Sitz und Rückenkissen aus hochelastischen Kaltschaum mit Abdeckung aus Daunen. Metallgestell Chrom. Rückenkissen mittels Mechanismus verstellbar. Ausführung mit oder ohne Sitzauszug. Stoff und Alcantara Bezüge vollständig abziehbar.

Structure en bois massif et multiplis. Suspension avec sangles élastiques entrecroisées, évêtues de polyuréthane expansé indéformable et tissu de protection. Coussin d'assise et de dossier en mousse polyuréthane expansé avec couette en plume d'oie matelassée. Piètement en métal chromé. Coussin de dossier inclinable en 2 positions: haute ou basse. Option: assise relax jusqu' à 22 cm pour un maximum de confort. Revêtement en tissu ou en Alcantara déhoussable. En cuir le revêtement est fixe.

Nano

Divano
Sofa

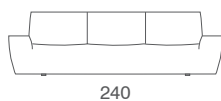

Pouf
Pouf

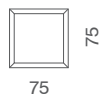

Cuscini
Pillows



Design: studio tecnico Gyform

Struttura in legno rivestita con poliuretano espanso indeformabile e trapuntino in piuma. Piedini in plastica. Il rivestimento è completamente sfoderabile.

Wood structure covered in polyurethane with covering in feather. Legs in PVC. Completely removable cover.

Gestell aus Holz, Polsteraufbau mit hochwertigen Schaumstoffen mit einer Abdeckung aus Daunen. Füße in Kunststoff. Bezüge vollständig abziehbar.

Structure en bois massif recouvert de mousse polyuréthane et couette en plume. Pieds en plastique. Revêtement en tissu déhoussable.

Athos

Divano
Sofa

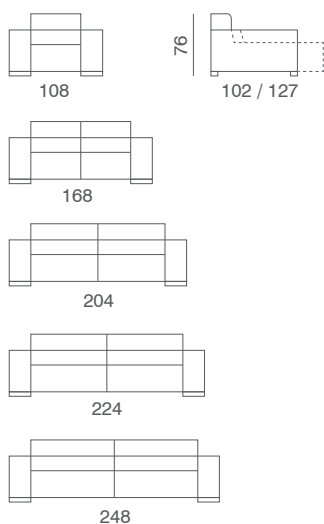

Elemento centrale
Central unit

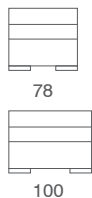

Elemento laterale dx o sx
Right or left unit

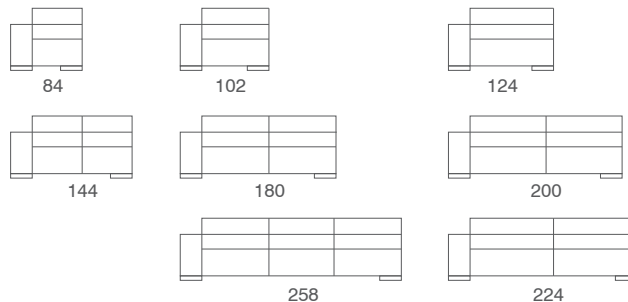

Dormeuse
Dormeuse

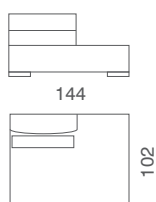

Chaise longue dx o sx
Chaise longue with right or left short arm

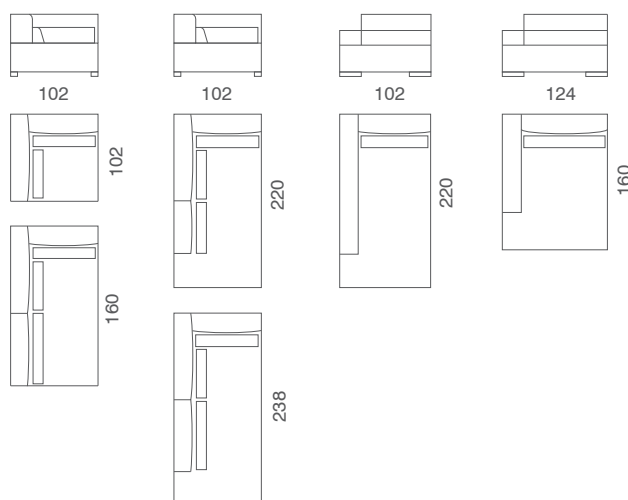

Pouf
Pouf

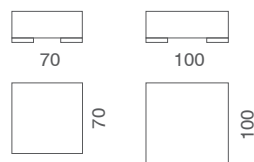

Cuscini
Pillows



Design: studio tecnico Gyform

Struttura in legno con cinghie elastiche rivestita con poliuretano espanso indeformabile e tessuto protettivo accoppiato. Cuscini seduta in poliuretano espanso indeformabile con trapuntino in piuma. Cuscini schienale in poliuretano espanso e "memory form" con trapuntino in piuma. Piedini ovali in alluminio oppure base in legno laccato nero. Rivestimento in tessuto sfoderabile. In pelle è fisso. Seduta estraibile in 4 diverse posizioni.

Hard wood structure covered in polyurethane with a protective fabric lining. Interwoven elastic webbing. Seat cushions in polyurethane covered with layer in feather. Back cushions in polyurethane and "memory form" covered with layer in feather. Oval Legs in aluminium or base in wood black lacquered. Completely removable fabric upholstery. Leather covering is fixed. Seat with relax system.

Gestell aus Massivholz, Polsteraufbau mit hochwertigen Schaumstoffen. Korpusbezug aus weißem Nylonvelour. Sitzaufbau des Federgrundes mit geprüften Trambolin-Gummigurten dicht bespannt. Sitzkissen aus hochelastischem Kaltschaum und Daunen. Rückenkissen aus hochelastischem Kaltschaum mit "Memory Form" und Daunen. Füße aus Aluminium oder Sockel schwarz lackiert aus Holz. Stoff Bezüge vollständig abziehbar. Sitzkissen mit Relaxausführung.

Structure en bois massif avec sangles élastiques entrecroisées revêtues de polyuréthane expansé indéformable et tissu de protection assorti. Coussin d'assise en polyuréthane expansé indéformable avec matelassé en plume. Coussin de dossier en polyuréthane expansé indéformable et "Memory Form" avec matelassé en plume. Pieds aluminium ou socle en bois noir. Coussin d'assise avec mécanisme. Revêtement en tissu déhoussable. En cuir le revêtement est fixe.

Athos Mini

Divano
Sofa

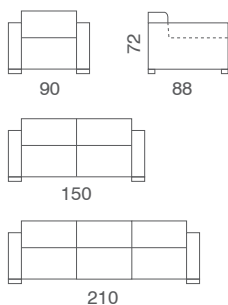

Design: studio tecnico Gyform

Struttura in legno con cinghie elastiche rivestita con poliuretano espanso indeformabile e tessuto protettivo accoppiato. Cuscini seduta in poliuretano espanso indeformabile con trapuntino in piuma. Cuscini schienale in poliuretano espanso e "memory form" con trapuntino in piuma. Piedini ovali in alluminio oppure base in legno laccato nero. Rivestimento in tessuto sfoderabile. In pelle è fisso.

Hard wood structure covered in polyurethane with a protective fabric lining. Interwoven elastic webbing. Seat cushions in polyurethane covered with layer in feather. Back cushions in polyurethane and "memory form" covered with layer in feather. Oval Legs in aluminium or base in wood black lacquered. Completely removable fabric upholstery. Leather covering is fixed.

Gestell aus Massivholz, Polsteraufbau mit hochwertigen Schaumstoffen. Korpusbezug aus weißem Nylonvelour. Sitzaufbau des Federgrundes mit geprüften Trambolin-Gummigurten dicht bespannt. Sitzkissen aus hochelastischem Kaltschaum und Daunen. Rückenkissen aus hochelastischem Kaltschaum mit "Memory Form" und Daunen. Füße aus Aluminium oder Sockel schwarz lackiert aus Holz. Stoff Bezüge vollständig abziehbar.

Structure en bois massif avec sangles élastiques entrecroisées revêtues de polyuréthane expansé indéformable et tissu de protection assorti. Coussin d'assise en polyuréthane expansé indéformable avec matelassé en plume. Coussin de dossier en polyuréthane expansé indéformable et "Memory Form" avec matelassé en plume. Pieds aluminium ou socle en bois noir. Revêtement en tissu déhoussable. En cuir le revêtement est fixe.

Domino

Divano
Sofa

Elemento laterale dx o sx
Right or left unit

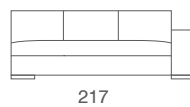
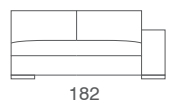
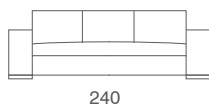
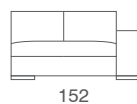
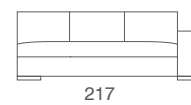
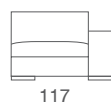
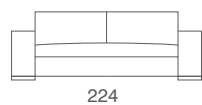
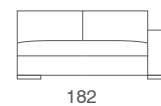
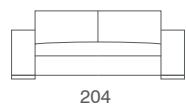
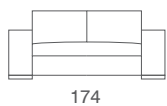
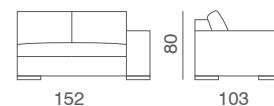
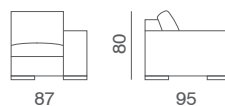
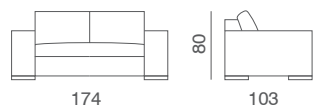
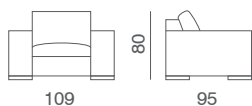

Design: studio tecnico Gyform

Struttura in legno con cinghie elastiche rivestita con poliuretano espanso indeformabile e tessuto protettivo accoppiato. Cuscini seduta in poliuretano espanso indeformabile a densità differenziata rivestito con falde di fibre acriliche e tela di corone. Cuscini schienale in piumaroll (miscela 70% piuma e 30% Dacron); braccioli in piuma. Piedini in acciaio satinato o lucido. Rivestimento in tessuto sfoderabile. In pelle è fisso.

Hard wood structure covered in polyurethane with a protective fabric lining. Interwoven elastic webbing. Seat cushions in polyurethane and Dacron. Back cushions with filling in "Piumaroll" (goose down mixed with 30% Dacron). Loose pillows in goose down. Legs in steel polished or mat. Completely removable fabric upholstery. Leather covering is fixed.

Gestell aus Massivholz, Polsteraufbau aus hochwertigen Schaumstoffen. Korpusbezug aus weißen Nylonvelour. Sitzaufbau des Federgrundes mit geprüften Trambolin Gummigurten dicht bespannt. Sitzkissen aus hochelastischem Kaltschaum und Dacron. Rückenkissen aus "Piumaroll" (Mischung 70% Daunen mit 30% Dacron). Armlehnen kissen aus Daunen. Füße aus Edelstahl gebürstet oder poliert. Stoff Bezüge vollständig abziehbar.

Structure en bois avec sangles élastiques revêtus de polyuréthane expansé indéformable et de tissu de protection assorti. Coussin d'assise en polyuréthane expansé indéformable de densité variable revêtus d'une housse acrylique toile de coton. Coussins de dossier et accoudoir an plume mélangées (70% plume et 30% polyuréthane). Pieds en acier satiné ou brillant. Revêtement en tissu déhoussable. En cuir le revêtement est fixe.

Domino

Elemento centrale
Central unit

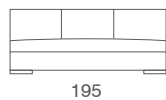
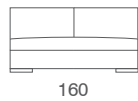
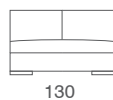
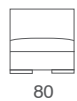
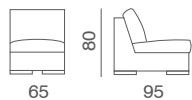

Chaise longue dx o sx
Chaise longue with right or left short arm

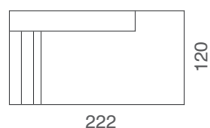
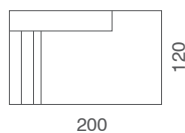
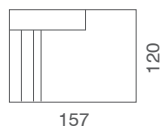
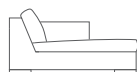
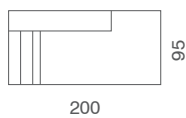
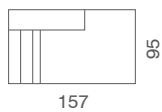
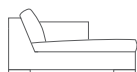

Angolo dx o sx
Right or left corner

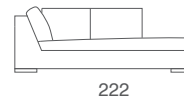
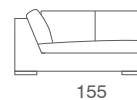
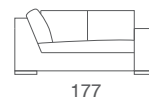
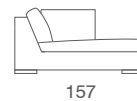
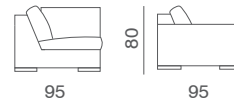

Pouf
Pouf



Dormeuse
Dormeuse

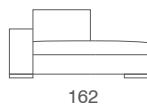
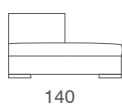

Cuscini
Pillows

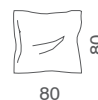

Egoista

Divano
Sofa

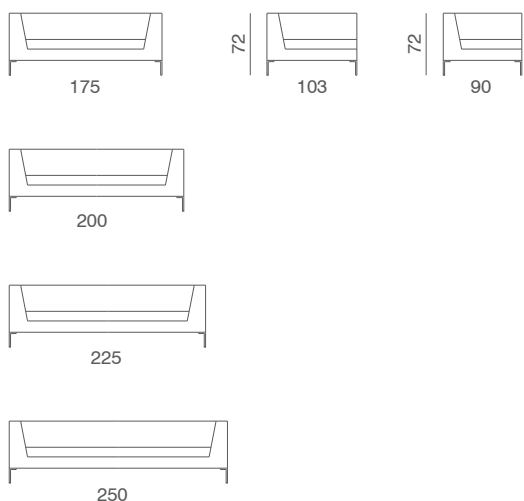

Elemento laterale dx o sx
Right or left unit

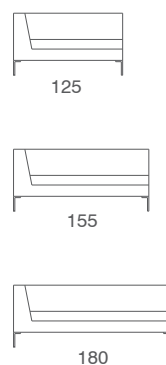

Chaise longue dx o sx
Chaise longue with right or left short arm

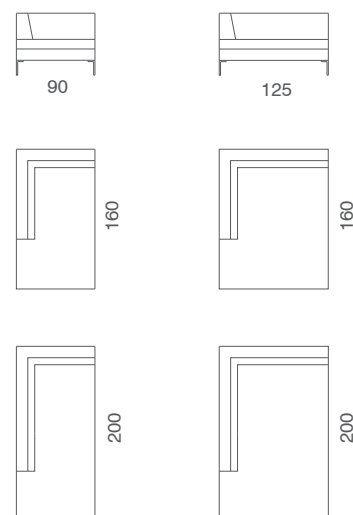

Pouf
Pouf

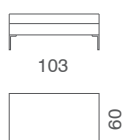

Cuscini
Pillows



Design: studio tecnico Gyform

Struttura in legno con cinghie elastiche rivestita con poliuretano espanso indeformabile e tessuto protettivo accoppiato. Cuscini seduta in poliuretano espanso indeformabile e Dacron. Cuscini schienale in piuma. Piedini in alluminio lucido. Rivestimento in tessuto foderabile. In pelle è fisso.

Hard wood structure covered in polyurethane with a protective fabric lining. Interwoven elastic webbing. Seat cushions in polyurethane and Dacron. Goose down arm and backrest cushions. Aluminium legs. Completely removable fabric upholstery. Leather covering is fixed.

Gestell aus Massivholz, Polsteraufbau mit hochwertigen Schaumstoffen. Korpusbezug aus weißen Nylonvelour. Sitzaufbau des Federgrundes mit geprüften Trambolin-Gummigurten dicht bespannt. Sitzkissen aus hochelastischen Kaltschaum und Dacron. Rückenkissen in Daunen. Füße aus Aluminium poliert. Stoff Bezüge vollständig abziehbar.

Structure en bois massif avec sangles élastiques entrecroisées revêtues de polyuréthane expansé indéformable et tissu de protection assorti. Coussin d'assise en polyuréthane et Dacron. Pied en aluminium brillant ou mat. Revêtement en tissu déhoussable. En cuir le revêtement est fixe.

Big Ben

Divano
Sofa

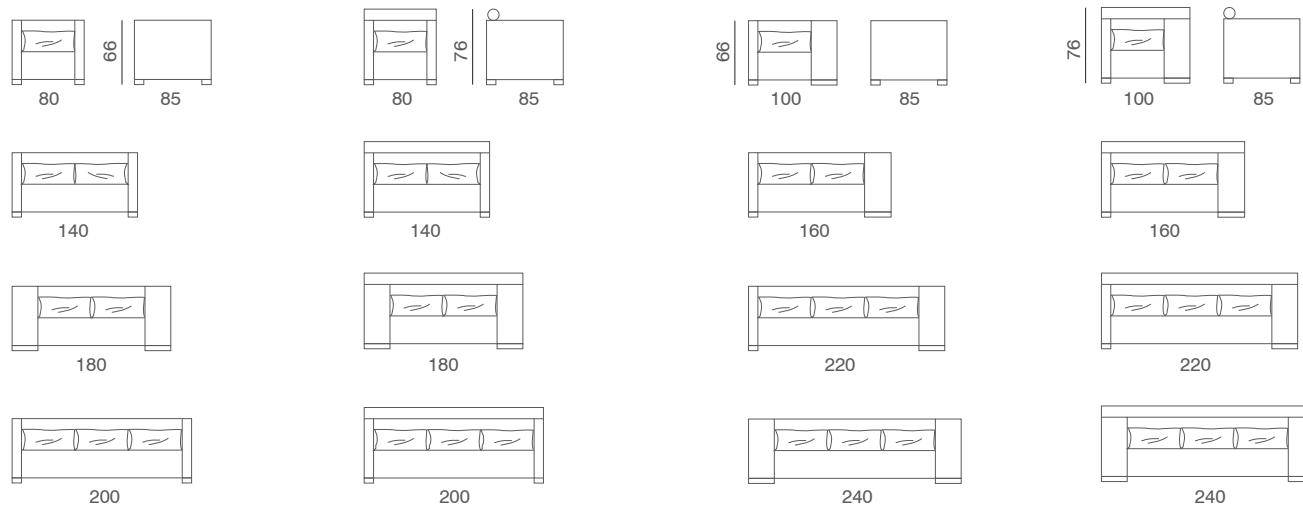

Pouf
Pouf

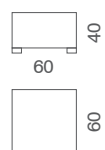

Design: studio tecnico Gyform

Struttura in legno con cinghie elastiche rivestita con poliuretano espanso indeformabile e tessuto protettivo accoppiato. Cuscini seduta e schienale in poliuretano espanso indeformabile e Dacron. Cuscinetto appoggiareni in piuma. Piedini in legno di faggio laccato oppure in acciaio. Rivestimento in tessuto sfoderabile. In pelle è fisso.

Hard wood structure covered in polyurethane with a protective fabric lining. Interwoven elastic webbing. Seat end back cushions in polyurethane and Dacron. Goose down back cushions. Legs in lacquered beech wood or in steel (mat or polished). Completely removable fabric upholstery.

Gestell aus Massivholz, Polsteraufbau aus hochwertigen Schaumstoffen. Korpusbezug aus weißen Nylonvelour. Sitzaufbau des Federgrundes mit geprüften Trambolin Gummigurten dicht bespannt. Sitz und Rückenkissen aus hochelastischen Kaltschaum und Dacron. Füße aus belassenem Buchenholz. Stoff Bezüge vollständig abziehbar.

Structure en bois avec bandes élastiques, revêtue en polyuréthane indéformable et en tissu protecteur. Coussin d'assise et de dossier en polyuréthane indéformable et dacron. Coussins calle rein en plumes. Pieds en bois ou en acier brillant ou mat. Revêtement en tissu déhoussable. En cuir le revêtement est fixe.

Composit

Divano
Sofa

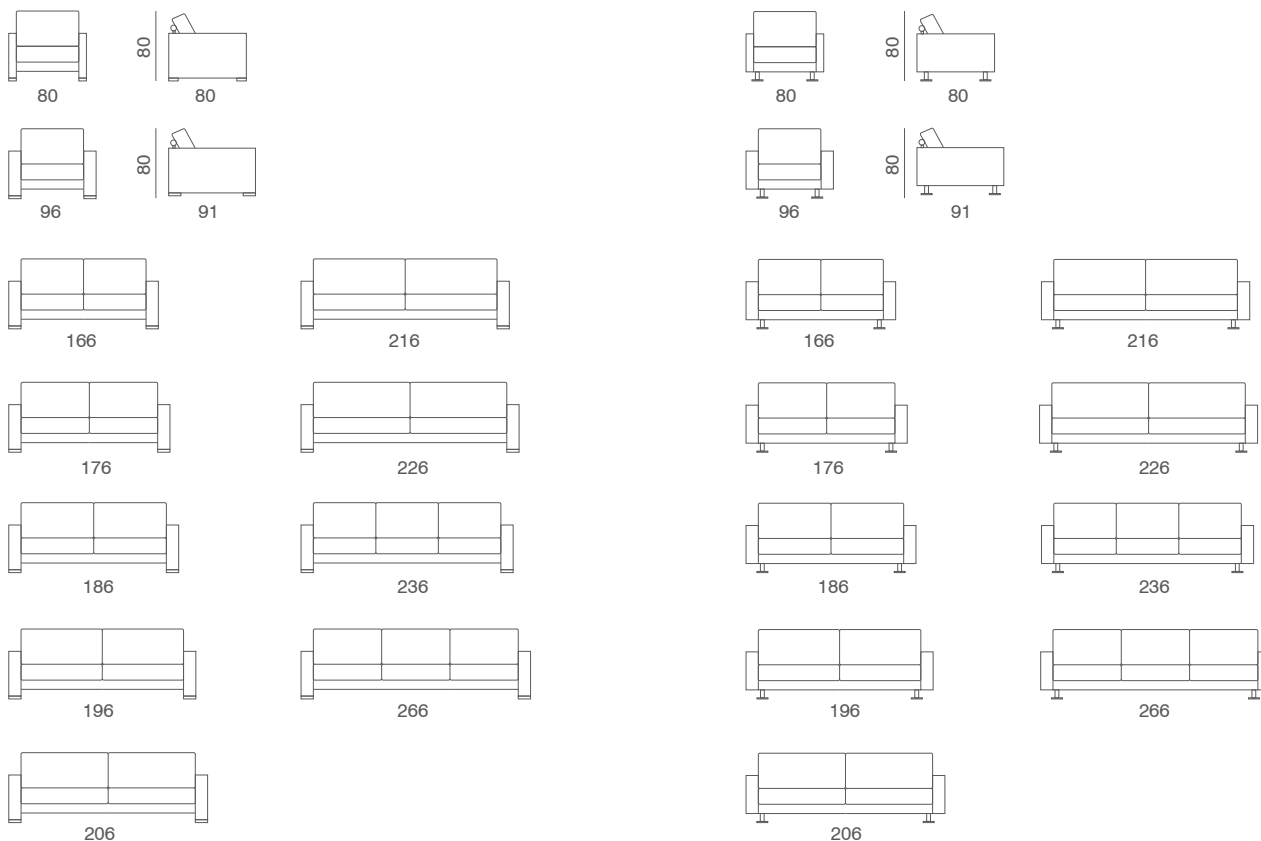

Design: studio tecnico Gyform

Struttura in legno con cinghie elastiche rivestita con poliuretano espanso indeformabile e tessuto protettivo accoppiato. Cuscini seduta in poliuretano espanso indeformabile e Dacron. Cuscini schienale piumaroll (miscela 70% piuma e 30% Dacron); braccioli in piuma. Versione con tubo poggiatesta in legno o acciaio oppure con rulli regolabili; Composit "A" con piedino a placca cm 13x13x2 cm in acciaio o legno su bracciolo e piedini cilindrici dove non c'è il bracciolo; Composit "B" e elementi senza braccioli con piedini cilindrici alti 10 cm in legno o acciaio. Rivestimento in tessuto sfoderabile, in pelle è fisso.

Hard wood structure covered in polyurethane with a protective fabric lining. Interwoven elastic webbing. Seat cushions in polyurethane and Dacron. Back cushions in "Piumaroll" (goose down mixed with 30% Dacron). Steel or wood back tube support or roll headrest adjustable; Composit "A" with metal plate 13x13x2 cm on the arm and cylinder legs on other side; Composit "B" and all element without arm with cylinder legs in beech wood or steel. Completely removable fabric upholstery. Leather covering is fixed.

Gestell aus Massivholz, Polsteraufbau aus hochwertigen Schaumstoffen. Korpusbezug aus weißen Nylonvelour. Sitzaufbau des Federgrundes mit geprüften Trambolin Gummigurten dicht bespannt. Sitz aus sandwichaufgebauten hochelastischen kaltschaum-Kombinationen 35/40kg. Abdeckung mit Dacron. Rückenkissen aus "Piumaroll" (Mischung 70% Daunen mit 30% Dacron). Armlehnen kissen aus Daunen. Ausführung mit Edelstahl oder Holz Rueckenstutze oder mit Rolle Kopfstutze verstellbar. Composit "A" mit Bodenplatten 13x13x2 cm aus Edelstahl oder Holz beim Armlehnen und Stellfüße bei andere Seiten; Composit "B" und alle andere Elemente mit Stellfüße aus Buchenholz oder Edelstahl. Stoff Bezüge vollständig abziehbar.

Structure en bois avec sangles elastiques révetues de polyurethane expansé indeformable et de tissu de protection assorti. Coussin d'assise en polyurethane expansé indeformable de densité variable revêtus d'une housse acrylique toile de coton. Coussins de dossier et accoudoir en plume mélangées (70% plume et 30% polyurethane). Tube appui tête en acier ou en bois ou rouleau appui tête revêtu. Composit « A » avec pieds 13x13x2 cm en acier satiné ou brillant ou en bois sur le accoudoir (pieds hauteur 10cm outre position); Composit "B" avec pieds H10 cm en acier satiné ou brillant ou en bois. Revêtement en tissu déhoussable. En cuir le revêtement est fixe.

Composit

Elemento centrale
Central unit

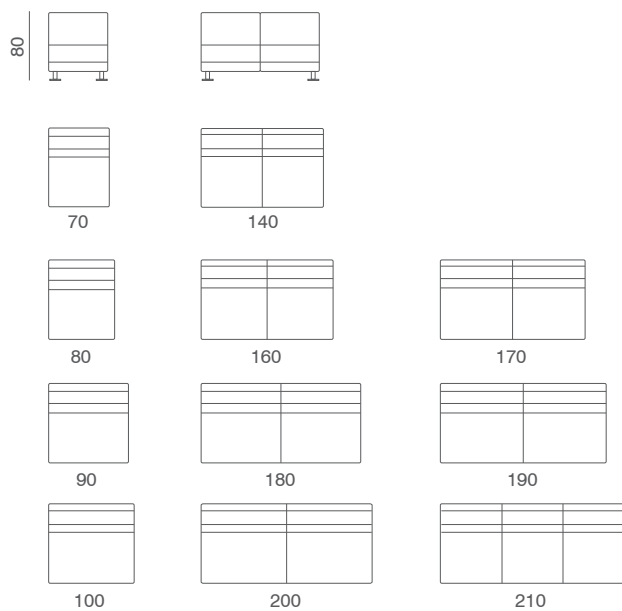

Angolo dx o sx
Right or left corner

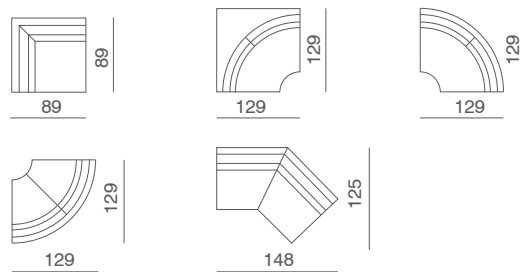

Chaise longue dx o sx
Chaise longue with right or left short arm

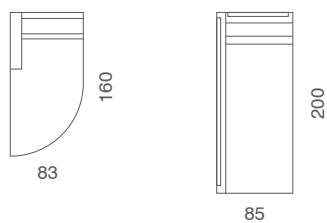

Pouf
Pouf

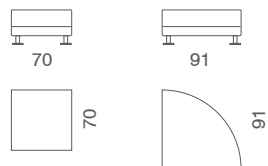

Cuscini
Pillows

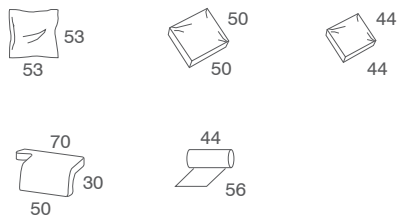

Doge

Divano
Sofa

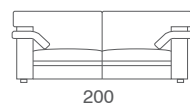
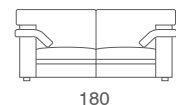
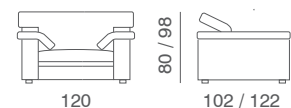

Elemento laterale dx o sx
Right or left unit

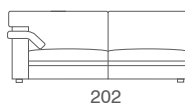
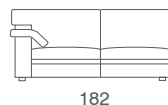
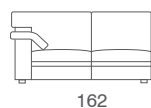
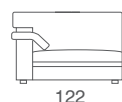
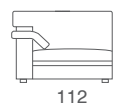
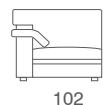

Elemento centrale
Central unit

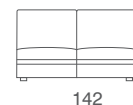

Chaise longue dx o sx
Chaise longue with right or left short arm

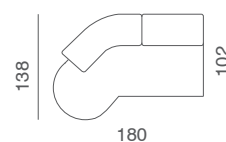
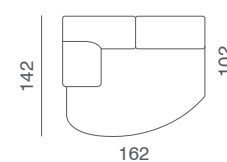
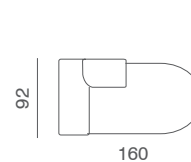
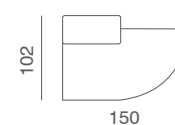
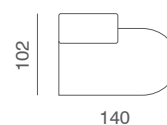

Angolo dx o sx
Right or left corner

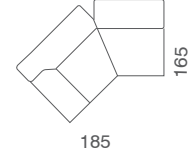
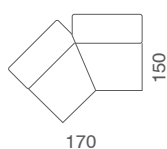
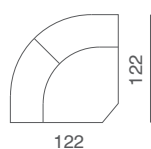
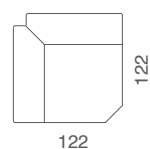
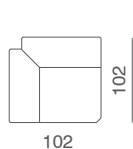

Pouf
Pouf



Design: studio tecnico Gyform

Struttura in legno con cinghie elastiche rivestita con poliuretano espanso indeformabile e tessuto protettivo accoppiato. Cuscini seduta in poliuretano espanso indeformabile e Dacron; cuscini schienale in piuma con supporto in poliuretano espanso. Cuscini braccioli in piuma. Piedini cilindrici diametro 6 cm alti 4 cm in faggio tinto oppure piedino Malibù 15x15x5 cm in alluminio satinato su bracciolo (nella versione componibile dove non c'è il bracciolo vengono usati in questo caso i piedini cilindrici Osaka diametro 5 cm in alluminio satinato). Rivestimento in tessuto sfoderabile. In pelle è fisso. Seduta estraibile e schienale reclinabile in 4 diverse posizioni.

Hard wood structure covered in polyurethane with a protective fabric lining. Interwoven elastic webbing. Seat cushions in polyurethane and Dacron; Goose down backrest cushions with resilient inner core. Arm cushions in goose down. Beech legs diameter 6 cm or mat aluminium legs Malibù 15x15x5 cm under the arm (by sectional shape where there is no arm will be used the cylinder aluminium leg Osaka). Completely removable fabric upholstery. Leather covering is fixed. Seat with relax system and backrest adjustable in four different positions.

Gestell aus Massivholz, Polsteraufbau mit hochwertigen Schaumstoffen. Korpusbezug aus weißen Nylonvelour. Sitzaufbau des Federgrundes mit geprüften Trambolin Gummigurten dicht bespannt. Sitzkissen aus hochelastischen Kaltschaum und Dacron-Rückenkissen in Daunen mit Innenverstärkung aus Kaltschaum. Armauflagekissen mit Federn gefüllt. Füße aus naturbelassenem Buchenholz Durchmesser 6 cm oder Füße Malibù 15x15x5 cm aus Alu gebürstet unter Armteil (beim Eckerguppe wo es gibt kein Armteil werden benutzt zylindrische Füße Osaka aus Alu gebürstet). Stoff Bezüge vollständig abziehbar. Sitzkissen mittels Mechanismus vierfach verstellbar.

Structure en bois avec sangles élastiques entrecroisées revêtues de polyuréthane expansé indéformable et de tissu de protection assorti. Coussin d'assise en polyuréthane expansé et dacron. Coussins de dossier en plume avec support en polyuréthane expansé. Coussins d'accoudoir en plume. Pieds cylindriques diamètre 6 cm, hauteur 4 cm en hêtre massif teinté ou autrement pied Malibù 15x15x5 cm en aluminium satiné. Revêtement en tissu déhoussable. En cuir le revêtement est fixe. Assise relax et dossier inclinable en 4 position différentes.

Mito A

Divano
Sofa

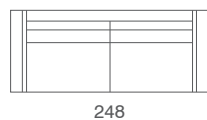
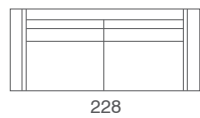
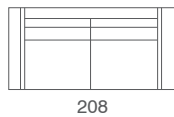
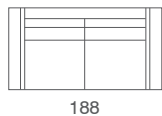
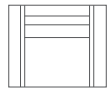
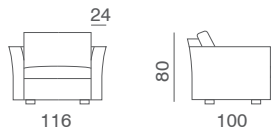

Pouf
Pouf

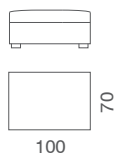

Elemento laterale dx o sx
Right or left unit

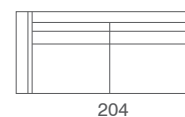
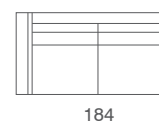
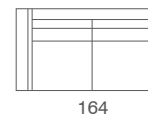
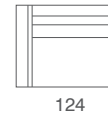

Cuscini
Pillows



Elemento centrale
Central unit

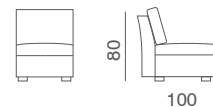

Angolo dx o sx
Right or left corner

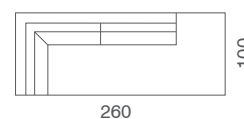
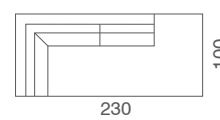
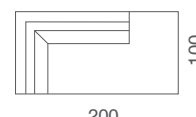

Chaise longue dx o sx
Chaise longue with right or left short arm

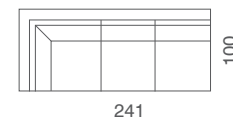
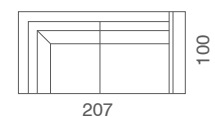
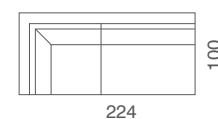
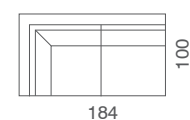
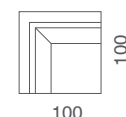
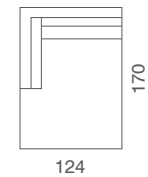
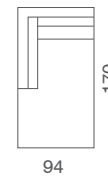

Design: studio tecnico Gyform

Struttura in legno con cinghie elastiche rivestita con poliuretano espanso indeformabile e tessuto protettivo accoppiato. Cuscini seduta in poliuretano espanso indeformabile e Dacron oppure in piuma con inserto; cuscini schienale e braccioli in piuma. Piedini in legno. Rivestimento in tessuto sfoderabile. In pelle è fisso.

Hard wood structure covered in polyurethane with a protective fabric lining. Interwoven elastic webbing. Seat cushions in polyurethane and Dacron or in goose down with resilient inner core; back cushions and arm in goose down. Legs in beech wood lacquered. Completely removable fabric upholstery. Leather covering is fixed.

Gestell aus Massivholz, Polsteraufbau mit hochwertigen Schaumstoffen. Korpusbezug aus weißen Nylonvelour. Sitzaufbau des Federgrundes mit geprüften Trambolin Gummigurten dicht bespannt. Sitzkissen aus hochelastischen Kaltschaum und Dacron oder mit Federn gefüllt und unverformbarer Innenverstärkung. Armlehnen und Rückenkissen in Daunen. Füße aus Holz gebeizt. Stoff Bezüge vollständig abziehbar.

Structure en bois avec bandes élastiques, revêtue en polyuréthane indéformable et en tissu protecteur. Coussin d'assise en polyuréthane indéformable et dacron ou en plume d'oie avec renfort en polyuréthane; coussins dossiers et d'accoudoir en plumes. Pieds en bois. Revêtement en tissu déhoussable. En cuir le revêtement est fixe.

Mixer New

Divano
Sofa

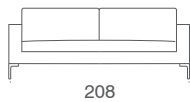
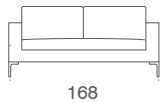
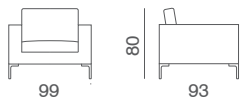

Elemento laterale dx o sx
Right or left unit

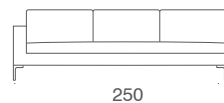
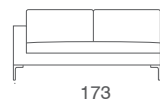
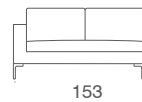
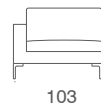

Elemento centrale
Central unit

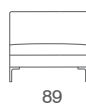

Pouf
Pouf



Cuscini
Pillows

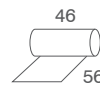

Chaise longue dx o sx
Chaise longue with right or left short arm

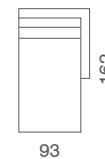
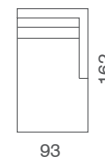

Design: studio tecnico Gyform

Struttura in legno con cinghie elastiche rivestita con poliuretano espanso indeformabile e tessuto protettivo accoppiato. Cuscini seduta in poliuretano espanso indeformabile e Dacron; cuscini schienale e braccioli in piuma; Mixer Mini con schienali in espanso e Dacron; piedini Mixer oppure piedini a lama "L" in alluminio cromato lucido o satinato. Rivestimento in tessuto sfoderabile. In pelle è fisso.

Hard wood structure covered in polyurethane with a protective fabric lining. Interwoven elastic webbing. Seat cushions in polyurethane and Dacron; back cushions and arm in goose down. Mixer Mini with back cushion in foam and Dacron; chrome-plated metal legs or lama "L" leg in aluminium polished or mat. Completely removable fabric upholstery. Leather covering is fixed.

Gestell aus Massivholz, Polsteraufbau mit hochwertigen Schaumstoffen. Korpusbezug aus weißen Nylonvelour. Sitzaufbau des Federgrundes mit geprüften Trambolin Gummigurten dicht bespannt. Sitzkissen aus hochelastischen Kaltschaum und Dacron, Armlehnen und Rückenkissen in Daunen. Füße Mixer oder Fuß Lama "L" Form Aluminiumpoliert oder gebürstet. Stoff Bezüge vollständig abziehbar.

Structure en bois avec bandes élastiques, revêtue en polyuréthane indéformable et en tissu protecteur. Coussin d'assise en polyuréthane indéformable et dacron; coussins dossiers et d'accoudoir en plumes (Mixer Mini avec coussin dossier en polyuréthane indéformable et dacron); Pieds en chrome brillant ou satiné, autrement pieds lama "L" aluminium. Revêtement en tissu déhoussable. En cuir le revêtement est fixe.

Mixer Mini

Divano
Sofa

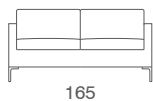
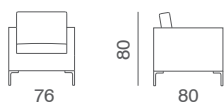

Design: studio tecnico Gyform

Struttura in legno con cinghie elastiche rivestita con poliuretano espanso indeformabile e tessuto protettivo accoppiato. Cuscini seduta in poliuretano espanso indeformabile e Dacron; cuscini schienale e braccioli in piuma; Mixer Mini con schienali in espanso e Dacron; piedini Mixer oppure piedini a lama "L" in alluminio cromato lucido o satinato. Rivestimento in tessuto sfoderabile. In pelle è fisso.

Hard wood structure covered in polyurethane with a protective fabric lining. Interwoven elastic webbing. Seat cushions in polyurethane and Dacron; back cushions and arm in goose down. Mixer mini with back cushion in foam and Dacron; chrome-plated metal legs or lama "L" leg in aluminium polished or mat. Completely removable fabric upholstery. Leather covering is fixed.

Gestell aus Massivholz, Polsteraufbau mit hochwertigen Schaumstoffen. Korpusbezug aus weißen Nylonvelour. Sitzaufbau des Federgrundes mit geprüften Trambolin Gummigurten dicht bespannt. Sitzkissen aus hochelastischen Kaltschaum und Dacron, Armlehnen und Rückenkissen in Daunen. Füße Mixer oder Fuß Lama "L" Form Aluminiumpoliert oder gebürstet. Stoff Bezüge vollständig abziehbar.

Structure en bois avec bandes élastiques, revêtue en polyuréthane indéformable et en tissu protecteur. Coussin d'assise en polyuréthane indéformable et dacron; coussins dossiers et d'accoudoir en plumes (Mixer mini avec coussin dossier en polyuréthane indéformable et dacron); Pieds en chrome brillant ou satiné, autrement pieds lama "L" aluminium. Revêtement en tissu déhoussable. En cuir le revêtement est fixe.

Plan Letto

Plan letto A
Plan letto A

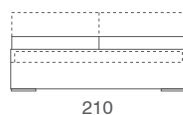
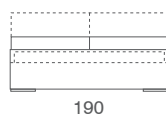
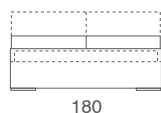
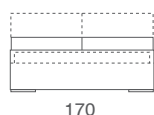
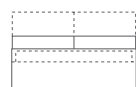
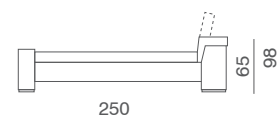

Plan letto B
Plan letto B

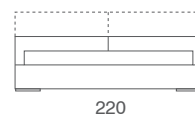
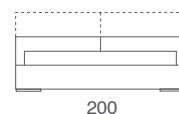
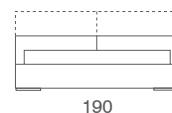
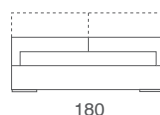
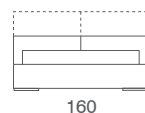
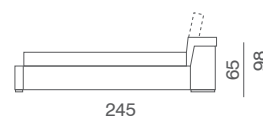

Design: studio tecnico Gyform

Struttura in legno rivestita con poliuretano espanso indeformabile e tessuto protettivo accoppiato. Cuscini schienale in espanso indeformabile e Dacron. Piedi in alluminio (satinato o lucido) oppure in metallo con finitura nikel nero. Cuscini schienale reclinabili in 2 posizioni (alta o bassa). Rivestimento in tessuto sfoderabile. In pelle è fisso.

Hard wood structure covered in polyurethane with a protective fabric lining. Back cushions in polyurethane and Dacron. Legs in black nikel-plated metal or in aluminium (mat or polished). Backrest are adjustable in 2 positions (high or down). Completely removable fabric upholstery. Leather covering is fixed.

Gestell aus Massivholz, Polsteraufbau mit hochwertigen Schaumstoffen. Korpusbezug aus weißen Nylonvelour. Rückenkissen aus hochelastischen Kaltschaum und Dacron. Metallplatte Nickel schwarz oder Aluminium (poliert oder matt). Rückenkissen mittels Mechanismus verstellbar. Stoff Bezüge vollständig abziehbar.

Structure en bois massif revêtu de polyuréthane expansé indéformable et tissu de protection assorti. Coussin de dossier en polyuréthane expansé indéformable et dacron. Pied en métal noir nikel ou aluminium. Coussin dossier inclinable en 2 différentes positions (haute ou basse). Revêtement en tissu déhoussable. En cuir le revêtement est fixe.

Chanel

Poltroncina
Armchair



Design: studio tecnico Gyform

Struttura della scocca in acciaio, interamente stampata in poliuretano schiumato a freddo. Sedile con inserto in legno, interamente stampato in poliuretano schiumato a freddo. Basamento in legno di faggio verniciato tinta naturale, ciliegio, noce medio, wengè, nero, tortora o in metallo cromato. Con maggiorazione di prezzo base girevole in metallo cromato a razze o con piatto. Rivestimento fisso (non sfoderabile).

Steel framework, entirely moulded in cold-cure polyurethane. Seat in wood moulded in cold-cure polyurethane. Stained beech wooden base in Natural, Cherry, Walnut, Wenge, Black, Dove or Chrome base. Swivel base (plate or 4 legs) available with upcharge. Cover is fixed (non-removable).

Metallrahmen, in Polyurethankalt vollständig geformt. Holzleisten an der Unterseite des Sitzes. Fusse aus Buche Farbe Natural, Kirsche, Nussbaum, wengè, schwarz oder Chrome. Mit extra Berechnung Basis drehbar mit Platte oder mit 4 Fusse. Bezüge nicht abziehbar.

Structure en acier, entièrement moulé à froid polyuréthane. Siège en bois. Pieds en hêtre teinté naturel, merisier, noyer, wengé, noir, tortora ou une base chromé. Option base pivotante avec pied central chromés ou plateau. Revêtement est fixe.

Sophie

Poltroncina
Armchair



Design: studio tecnico Gyform

Struttura della scocca in acciaio, interamente stampata in poliuretano schiumato a freddo. Sedile con inserto in legno, interamente stampato in poliuretano schiumato a freddo. Basamento in legno di faggio verniciato tinta naturale, ciliegio, noce medio, wengè, nero, tortora o in metallo cromato. Con maggiorazione di prezzo base girevole in metallo cromato a razze o con piatto. Rivestimento fisso (non sfoderabile).

Steel framework, entirely moulded in cold-cure polyurethane. Seat in wood moulded in cold-cure polyurethane. Stained beech wooden base in Natural, Cherry, Walnut, Wenge, Black, Dove or Chrome base. Swivel base (plate or 4 legs) available with upcharge. Cover is fixed (non-removable).

Stahlgestell, mit Polyurethankaltschaum geformt. Holzleisten an der Unterseite des Sitzes. Füsse aus Buche Farbe Natural, Kirsche, Nussbaum, Wengè, Schwarz oder Chrome. Gegen Aufpreis, Basis drehbar mit Platte oder mit 4 Füsse. Bezüge nicht abziehbar.

Structure en acier, entièrement moulé à froid polyuréthane. Siège en bois. Pieds en hêtre teinté naturel, merisier, noyer, wengé, noir, tortora ou une base chromé. Option base pivotante avec pied central chromés ou plateau. Revêtement est fixe.

Gaia

Poltroncina
Armchair



Design: studio tecnico Gyform

Struttura in legno con cinghie elastiche rivestita con poliuretano espanso indeformabile e tessuto protettivo accoppiato. Base in legno di faggio verniciato tinta wengè. Rivestimento in tessuto sfoderabile.

Hardwood structure covered in polyurethane and Dacron. Interwoven elastic webbing. Feet in beech wood lacquered wenge. Cover is completely removable.

Gestell aus Massivholz, Polsteraufbau mit hochwertigen Schaumstoffen und Dacronwatte. Sitzunterfederung mit geprüften Trambolin-Gummigurten dicht bespannt. Füße aus Buchenholz gebeizt wengefarbig. Bezüge abziehbar.

Structure en bois avec sangles XL élastiques entrecroisées revêtues de polyuréthane expansé et de tissu de protection assorti. Pieds en hêtre teinté wengé. Revêtement en tissu déhoussable.

Giò

Poltroncina
Armchair



Design: studio tecnico Gyform

Struttura della scocca in acciaio, interamente stampata in poliuretano schiumato a freddo. Sedile con inserto in legno, interamente stampato in poliuretano schiumato a freddo. Basamento in legno di faggio verniciato tinta naturale, ciliegio, noce medio, wengè, nero, tortora o in metallo cromato. Con maggiorazione di prezzo base girevole in metallo cromato a razze o con piatto. Rivestimento fisso (non sfoderabile).

Steel framework, entirely moulded in cold-cure polyurethane. Seat in wood moulded in cold-cure polyurethane. Stained beech wooden base in Natural, Cherry, Walnut, Wenge, Black, Dove or Chrome base. Swivel base (plate or 4 legs) available with upcharge. Cover is fixed (non-removable).

Stahlgestell, in Polyurethankaltschaum vollständig geformt. Holzleisten an der Unterseite des Sitzes. Füße aus Buche Farbe Natural, Kirsche, Nussbaum, Wengè, Schwarz oder Chrome. Gegen Aufpreis Basis drehbar mit Platte oder mit 4 Füße. Bezüge nicht abziehbar.

Structure en acier, entièrement moulé à froid polyuréthane. Siège en bois. Pieds en hêtre teinté naturel, merisier, noyer, wengé, noir, tortora ou une base chromé. Option base pivotante avec pied central chromés ou plateau. Revêtement est fixe.

Megane

Poltroncina
Armchair

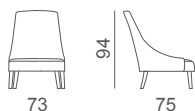

Design: studio tecnico Gyform

Struttura in legno con cinghie elastiche rivestita con poliuretano espanso indeformabile e tessuto protettivo accoppiato. Piedini in legno di faggio verniciato tinta naturale, ciliegio, noce medio, wengè, nero. Rivestimento fisso (non sfoderabile).

Hardwood structure covered in polyurethane and Dacron. Interwoven elastic webbing. Feet in natural lacquered beech wood. Cover is fixed (non-removable).

Gestell aus Massivholz, Polsteraufbau mit hochwertigen Schaumstoffen und Dacronwatte. Sitzunterfederung mit geprüften Trambolin-Gummigurten dicht bespannt. Füße aus Buchenholz gebeizt. Bezüge nicht abziehbar.

Structure en bois avec sangles XL élastiques entrecroisées revêtues de polyuréthane expansé et de tissu de protection assorti. Pieds en hêtre. Revêtement est fixe.

Chica

Poltroncina
Armchair

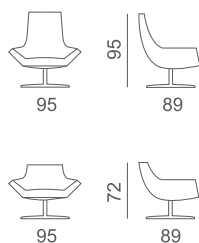

Design: studio tecnico Gyform

Struttura in metallo con cinghie elastiche rivestita con poliuretano espanso indeformabile e tessuto protettivo accoppiato. Base girevole piatto in acciaio inox oppure cromo lucido a razze. Rivestimento in tessuto sfoderabile. In pelle è fisso.

Metal structure covered in polyurethane with a protective fabric lining. Interwoven elastic webbing. Swivel base plate in matte steel or polished chrome. Completely removable fabric upholstery. Leather covering is fixed.

Das Gestell ist aus Metall. Der Polsteraufbau besteht aus hochwertigen Schaumstoffen. Korpusbezug aus weissen Nylonvelour. Sitzaufbau, Federgrund mit geprüften Trambolin Gummigurten dicht bespannt. Das Gestell ist drehbar aus flachen Edelstahl. Erhältlich in Aluminium matt oder poliert. Die Stoffbezüge sind vollständig abziehbar.

Structure en métal avec bandes élastiques, revêtue en polyuréthane indéformable et en tissu protecteur assorti. Base tournante en acier inox ou rayons luisants. Revêtement en tissu déhoussable. En cuir le revêtement est fixe.

Pouf
Pouf

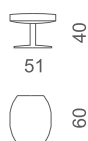

Butterfly

Poltroncina
Armchair

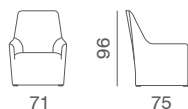

Design: studio tecnico Gyform

Struttura in legno con cinghie elastiche rivestita con poliuretano espanso indeformabile e tessuto protettivo accoppiato. Cuscini seduta e schienale in poliuretano espanso indeformabile e Dacron. Rivestimento in tessuto sfoderabile. In pelle è fisso.

Hard wood structure covered in polyurethane with a protective fabric lining. Interwoven elastic webbing. Seat and back cushions in polyurethane and Dacron. Completely removable fabric upholstery. Leather covering is fixed.

Gestell aus Massivholz, Polsteraufbau mit hochwertigen Schaumstoffen. Korpusbezug aus weißen Nylonvelour. Sitzaufbau des Federgrundes mit geprüften Trambolin Gummigurten dicht bespannt. Sitz und Rückenkissen aus hochelastischen Kaltschaum und Dacron. Stoff Bezüge vollständig abziehbar.

Structure en bois avec bandes élastiques, revêtue en polyuréthane indéformable et en tissu protecteur. Coussin d'assise et dossier en polyuréthane indéformable et dacron. Revêtement en tissu déhoussable. En cuir le revêtement est fixe.

Venus

Poltroncina
Armchair

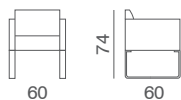

Design: studio tecnico Gyform

Struttura in legno con cinghie elastiche rivestita con poliuretano espanso indeformabile in densità differenziata, Dacron e tessuto protettivo accoppiato. Rivestimento in tessuto sfoderabile. In pelle è fisso. Piedini in alluminio lucido o satinato.

Hard wood structure covered in polyurethane foam in different densities, Dacron and protective fabric lining. Interwoven elastic webbing. Completely removable fabric upholstery. Leather covering is fixed. Legs in aluminium; polished or matte.

Das Gestell ist aus Massivholz, der Polsteraufbau aus hochwertigen Schaumstoffen. Der Korpusbezug aus weißen Nylonvelour. Der Sitzaufbau des Federgrundes ist aus Metall mit geprüften Trambolin Gummigurten dicht bespannt. Die Stoffbezüge sind vollständig abziehbar und waschbar. Die Füße sind aus Aluminium, poliert oder matt.

Structure en bois massif avec sangles élastiques entrecroisées revêtues de polyuréthane expansé indéformable et tissude protection assorti. Coussins d'assise et dossier en polyuréthane expansé indéformable et Dacron. Revêtement en tissu déhoussable, en cuir fixe. Pieds en aluminium brillant ou mat.

Bobo

Poltroncina
Armchair

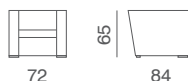

Design: studio tecnico Gyform

Struttura in legno con cinghie elastiche rivestita con poliuretano espanso indeformabile. Cuscino seduta in poliuretano espanso indeformabile e Dacron. Eventuale cuscinetto optional appoggia reni in piuma. Piedini anteriori in alluminio lucido o satinato. In tessuto il rivestimento è completamente sfoderabile.

Hard wood structure covered in polyurethane. Interwoven elastic webbing. Seat cushion in polyurethane and Dacron. As optional back loose round cushion in feather. Front legs in aluminium polished or mat. Completely removable fabric upholstery. Leather covering is fixed.

Gestell aus Massivholz, Polsteraufbau mit hochwertigen Schaumstoffen. Sitzaufbau des Federgrundes mit geprüften Trambolin Gummigurten dicht bespannt. Sitzkissen aus hochelastischem Kaltschaum und Dacron. Runde Nierenkissen optional in Daunen. Füße vorne aus Aluminium poliert oder gebürstet. Soff Bezüge vollständig abziehbar.

Structure en bois avec bandes élastiques, revêtue en polyuréthane indéformable et en tissu protecteur. Coussin d'assise en polyuréthane indéformable et dacron; coussins dossiers en plumes. Pieds en aluminium brillant ou mat. Revêtement en tissu déhoussable. En cuir le revêtement est fixe.

Enigma

Poltroncina
Armchair



Design: studio tecnico Gyform

Struttura in legno con cinghie elastiche rivestita con poliuretano espanso indeformabile e tessuto protettivo accoppiato. Cuscini seduta in poliuretano espanso indeformabile e Dacron. Piedini in alluminio lucido. Rivestimento in tessuto sfoderabile. In pelle è fisso.

Hard wood structure covered in polyurethane with a protective fabric lining. Interwoven elastic webbing. Seat cushions in polyurethane and Dacron. Aluminium legs. Completely removable fabric upholstery. Leather covering is fixed.

Divano
Sofa

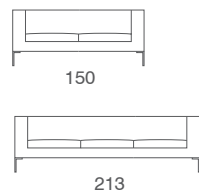

Gestell aus Massivholz, Polsteraufbau mit hochwertigen Schaumstoffen. Korpusbezug aus weißen Nylon velour. Sitzaufbau des Federgrundes mit geprüften Trambolin-Gummigurten dicht bespannt. Sitzkissen aus hochelastischen Kaltschaum und Dacron. Füße aus Aluminium poliert. Stoff Bezüge vollständig abziehbar.

Structure en bois massif avec sangles élastiques entrecroisées revêtues de polyuréthane expansé indéformable et tissu de protection assorti. Coussin d'assise en polyuréthane et Dacron. Pied en aluminium brillant ou mat. Revêtement en tissu déhoussable. En cuir le revêtement est fixe.

Natalie

Poltroncina
Armchair

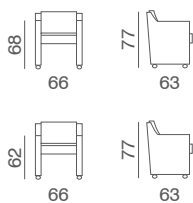

Design: studio tecnico Gyform

Struttura in legno con cinghie elastiche rivestita con poliuretano espanso indeformabile e tessuto protettivo accoppiato. Cuscino seduta e schienale in poliuretano espanso indeformabile e Dacron. Rivestimento in tessuto sfoderabile. In pelle è fisso. Con ruote oppure piedini in alluminio.

Hard wood structure. Interwoven elastic webbing. Seat & back in polyurethane with covering in dacron; Legs in aluminium polished. Completely removable fabric upholstery. With wheels or aluminium legs.

Gestell aus Massivholz. Sitzaufbau mit geprüften Trambolin-Gummigurten dicht bespannt. Sitzkissen und Rücken aus Schaum mit einer Dacron Abdeckung; Fuss Alu poliert. Stoff Bezüge vollständig abziehbar. Mit Rollen oder Alu Füße.

Structure en bois massif avec sangles élastiques XL tissées entrecroisées revêtues de polyuréthane expansé indéformable et de tissu de protection assorti. Revêtement en tissu déhoussable. En cuir le revêtement est fixe. Avec roulettes ou pieds aluminium.

Mix

Poltroncina
Armchair

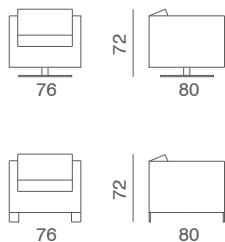

Design: studio tecnico Gyform

Struttura in legno con cinghie elastiche rivestita con poliuretano espanso indeformabile e tessuto protettivo accoppiato. Cuscini seduta e schienale in poliuretano espanso indeformabile e Dacron. Base girevole lucida o satinata o con piedini in alluminio (cromato satinato) o in legno. Rivestimento in tessuto sfoderabile. In pelle è fisso.

Hard wood structure covered in polyurethane with a protective fabric lining. Interwoven elastic webbing. Seat and back cushions in polyurethane and Dacron. Turning base chrome-plated or mat or aluminium legs (polished or mat) or in wooden legs. Completely removable fabric upholstery. Leather covering is fixed.

Gestell aus Massivholz, Polsteraufbau mit hochwertigen Schaumstoffen. Korpusbezug aus weißen Nylonvelour. Sitzaufbau des Federgrundes mit geprüften Trambolin Gummigurten dicht bespannt. Sitz und Rückenkissen aus hochelastischen Kaltschaum und Dacron. Drehbares Gestell (poliert oder matt) oder Füße aus Aluminium oder Holz Füße. Stoff Bezüge vollständig abziehbar.

Structure en bois avec bandes élastiques, revêtue en polyuréthane indéformable et en tissu protecteur. Coussin d'assise et dossier en polyuréthane indéformable et Dacron. Base tournante luisante ou mate ou pieds en aluminium ou en bois. Revêtement en tissu déhoussable. En cuir le revêtement est fixe.

Queen

Poltroncina
Armchair

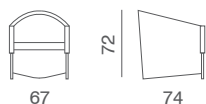

Design: studio tecnico Gyform

Struttura in legno con cinghie elastiche rivestita con poliuretano espanso indeformabile. Cuscino seduta in poliuretano espanso indeformabile e Dacron. Piedini in legno di faggio tinto, in alluminio o ricoperti in tessuto o pelle. Il rivestimento è fisso.

Hard wood structure covered in polyurethane. Interwoven elastic webbing. Seat cushion in polyurethane and Dacron. Feet in natural lacquered beech wood, aluminium or recovered with fabric or leather. Cover is fixed.

Gestell aus Massivholz, Polsteraufbau mit hochwertigen Schaumstoffen. Sitzaufbau des Federgrundes mit geprüften Trambolin-Gummigurten dicht bespannt Sitzkissen aus hochelastischem Kaltschaum und Dacron. Fusse aus naturbelassenem Buchenholz, Aluminium oder mit Leder/Stoff bezogen. Bezug nicht abziehbar.

Structure en bois massif avec sangles élastiques entrecroisées revêtues de polyuréthane expansé indéformable et tissu de protection assorti. Coussin d'assise en polyuréthane et Dacron. Pieds en bois, aluminium ou en cuir ou en tissu. Revêtement est fixe.

Clio

Chaise longue
Chaise longue

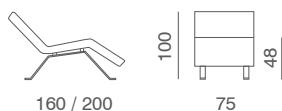

Design: studio tecnico Gyform

Struttura in metallo con cinghie elastiche rivestita con poliuretano espanso indeformabile e tessuto protettivo accoppiato. Piedini in metallo cromato. Rivestimento in tessuto sfoderabile. In pelle è fisso. Finitura rivestimento trapuntata o liscia. Schienale reclinabile in 6 diverse posizioni; poggiatesta regolabile in 3 diverse posizioni.

Metal frame covered in polyurethane with a protective fabric lining. Interwoven elastic webbing. Chrome-plated metal feet. Completely removable fabric upholstery. Leather covering is fixed. Cover finishing quilted or smooth. Backrest adjustable in 6 different positions and footrest in 3 positions.

Poggiatesta
Headrest



Gestell aus verchromten oder mattierten Metall, Polsteraufbau mit hochwertigen Schaumstoffen, geprüften Trambolin Gummigurten dicht bespannt. Stoff Bezüge vollständig abziehbar. Hussen Ausführungen gesteppt oder glatt. Rücken mittels Mechanismus sechsfach-verstellbar; Fußstütze dreifach-verstellbar.

Structure en métal avec bandes élastiques, revêtue en polyuréthane indéformable et en tissu protecteur. Piètement chromé ; Finition matelassé ou je lisse. Dossier relevable en 6 position différentes; appuie pieds relevable en 6 position différentes. Revêtement en tissu déhoussable. En cuir le revêtement est fixe.

Break

Tavolino
Table

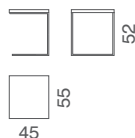
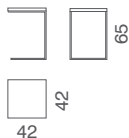

Design: studio tecnico Gyform

Impiallacciato rovere tinto wengè. Il supporto metallico è costituito da barre di acciaio satinato e lucido.

Wood plate oak veneered finishing wengè. Support in steel polished or mat.

Faserplatte aus Tannenholz mit Eichefurnier wengè farbig gebeizt. Gestell aus Edelstahl mat oder poliert.

Bois rouvre plaqué couleur wengè. Support en acier mat ou brillant.

Azalea Break

Tavolino
Table

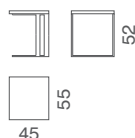
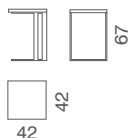

Design: studio tecnico Gyform

Impiallacciato rovere tinto wengè. Il supporto metallico è costituito da barre di acciaio satinato e lucido.

Wood plate oak veneered finishing wengè. Support in steel polished or mat.

Faserplatte aus Tannenholz mit Eichefurnier wengè farbig gebeizt. Gestell aus Edelstahl mat oder poliert.

Bois rouvre plaqué couleur wengè. Support en acier mat ou brillant.

Molly

Pouf
Pouf

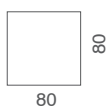
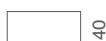
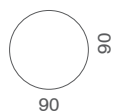

Design: studio tecnico Gyform

Imbottitura in microsfere di polistirolo. Rivestimento sfoderabile.

Filling in polystyrene microspheres. Remoivable cover.

Fuellung in Polystyrol-Mikrosphären; Bezug abziehbar.

Rembourrage dans des microsphères de polystyrène. Housse removable.

Ego

Pouf
Pouf



Design: studio tecnico Gyform

Struttura in legno rivestita con poliuretano espanso indeformabile e tessuto protettivo accoppiato. Rivestimento in tessuto sfoderabile. In pelle è fisso.

Hard wood structure covered in polyurethane with a protective fabric lining. Seat in polyurethane and Dacron. Completely removable fabric upholstery. Leather covering is fixed.

Gestell aus Massivholz, Polsteraufbau aus hochwertigen Schaumstoffen. Korpusbezug aus weißen Nylonvelour. Sitz aus hochelastischen Kaltschaum und Dacron. Stoff Bezüge vollständig abziehbar.

Structure en bois revêtues de polyuréthane expansé indéformable et tissu de protection assorti. Avec roulettes. Revêtement en tissu déhoussable.

Cubo

Pouf
Pouf



Design: studio tecnico Gyform

Struttura in legno rivestita con poliuretano espanso indeformabile e tessuto protettivo accoppiato. Rivestimento in tessuto sfoderabile. In pelle è fisso.

Hard wood structure covered in polyurethane with a protective fabric lining. With wheels; completely removable fabric upholstery.

Gestell aus Massivholz. Korpusbezug aus weißen Nylonvelour. Stoff Bezüge vollständig abziehbar. Mit Rollen oder Füsse.

Structure en bois revêtues de polyuréthane expansé indéformable et tissu de protection assorti. Avec roulettes. Revêtement en tissu déhoussable.

MADE IN ITALY 100%

Azienda certificata
UNI EN ISO 9001:2008

*An UNI EN ISO 9001:2008
certified Company*



Certificate No.
09-Q-00202-TIC



**CONTATTI /
CONTACTS**

Gyform srl
Via Al Sarca, 7
38080 Vigo Rendena TN
Italy
T. +39 0465 801041
F. +39 0465 801253

info@gyform.it
www.gyform.it

**CREDITI /
CREDITS**

Art Direction:
Alessia Gasperi

Photo:
IKB
Foto Fox Studio

Made and printed
in Italy, September 2015
by Esperia

